



County of Fresno

DEPARTMENT OF PUBLIC WORKS AND PLANNING
STEVEN E. WHITE, DIRECTOR

Planning Commission Staff Report Agenda Item No. 5 October 13, 2022

- SUBJECT:** **Unclassified Conditional Use Permit Application No. 3747**
- Amend previously approved Unclassified Conditional Use Permit 2991 to allow the development of additional on-site parking for the Riverdale Memorial District. The project is located on two adjacent parcels, a 1.50-acre and 1.27-acre parcel in the R-1 (Single-Family Residential) Zone District.**
- LOCATION:** **The parcels are located on the southeast corner of W. Mt. Whitney Ave. and S. Feland Ave., located in the unincorporated community of Riverdale (APN: 053-260-08T & 053-260-09ST) (3085 W. Mt. Whitney Ave.) (Sup. Dist. 4).**
- OWNER:** **Richard Schultz**
- APPLICANT:** **Kenny Reyes**
- STAFF CONTACT:** **Ricky Vang, Planner**
 (559) 600-4224
- David Randall, Senior Planner**
 (559) 600-4052
- RECOMMENDATION:**
- Approve Unclassified Conditional Use Permit No. 3747 with recommended Findings and Conditions; and
 - Direct the Secretary to prepare a Resolution documenting the Commission's action.

EXHIBITS:

1. Conditions of Approval and Project Notes
2. Location Map
3. Existing Zoning Map
4. Existing Land Use Map
5. Site Plan
6. Operational Statement
7. Photos

SITE DEVELOPMENT AND OPERATIONAL INFORMATION:

Criteria	Existing	Proposed
General Plan Designation	Residential	No change
Zoning	R-1 (Single Family Residence)	No change
Parcel Size	APN's 053-260-08T: 1.5-acres 053-260-09ST: 1.27-acres	No change
Project Site	Riverdale Memorial District Event Center	Construct onsite parking
Structural Improvements	Riverdale Memorial District Event Center	Additional parking surfaces and travel lanes
Nearest Residence	500 feet north-east	No change
Surrounding Development	Agriculture, Single-Family Residences, School, Church	No change
Operational Features	Existing onsite parking lot unstriped 7 Standard 2 ADA	Increase parking of 17 Standard 2 ADA 5 Motorcycle
Employees	2 part time employees	No change
Customers	N/A	N/A
Traffic Trips	Based on event	No change

Criteria	Existing	Proposed
Lighting	Pole lighting for parking area, access roads, and exterior building lighting	Pole lighting added to new onsite parking lot and driveway
Hours of Operation	Based on event	No change

EXISTING VIOLATION (Y/N) AND NATURE OF VIOLATION: N

ENVIRONMENTAL ANALYSIS:

It has been determined, pursuant to Section 15301, “Existing Facilities” of the State of California Environmental Quality Act Guidelines (CEQA) that this proposal is Categorically exempt from CEQA requirements.

PUBLIC NOTICE:

Notices were sent to 33 property owners within 600 feet of the subject parcel, exceeding the minimum notification requirements prescribed by the California Government Code and County Zoning Ordinance.

PROCEDURAL CONSIDERATIONS:

An Unclassified Conditional Use Permit may be approved only if the five Findings specified in the Fresno County Zoning Ordinance, Section 873-F are made by the Planning Commission.

The decision of the Planning Commission on an Unconditional Use Permit Application is final, unless appealed to the Board of Supervisors within 15 days of the Commission’s action.

BACKGROUND INFORMATION:

The Riverdale Memorial District is a public facility that is rented out for a variety of purposes, including business meetings, private parties, weddings, sporting events, and community gatherings.

The construction of the existing facility in 1953 predates a requirement of the Zoning Ordinance. The use was memorialized in 2001 through approval of an Unclassified Conditional Use Permit No. 2991.

The application purposes to allow additional onsite parking. The project does not expand the capacity of the Memorial Hall. The first purposed parking lot will consist of 7 standard stalls, 2 ADA compliant stalls and 5 motorbike stalls. Second parking lot includes 10 standard stalls. The current existing onsite parking will also be re-striped with 7 standard stalls and 2 ADA stalls.

Finding 1: That the site of the proposed use is adequate in size and shape to accommodate said use and all yards, spaces, walls and fences, parking, loading, landscaping, and other features required by this Division, to adjust said use with land and uses in the neighborhood.

	Current Standard:	Proposed Operation:	Is Standard Met (y/n)
Setbacks	R1 Front: 20 feet Side: 5 feet Rear: 20 feet	No change	Y
Parking	One space for every dwelling unit	No change	Y
Lot Coverage	Not to exceed 40% of total lot area	No change	Y
Space Between Buildings	Minimum 6 feet from main building	No change	Y
Wall Requirements	No Requirement	No change	N/A
Septic Replacement Area	N/A	N/A	N/A
Water Well Separation	N/A	N/A	N/A

Reviewing Agency/Department Comments Regarding Site Adequacy:

No comments specific to the adequacy of the site were expressed by reviewing Agencies or Departments.

Finding 1 Analysis:

A review of the site plan demonstrates that all proposed structures meet minimum building setback requirements of the R-1 Zone District. As the parking has no structures over it, there are no relative setback issues. The site is adequate in size and shape to accommodate the proposed use, including parking, circulation, and ingress/egress.

Recommended Conditions of Approval:

None.

Finding 1 Conclusion:

Finding 1 can be made as the proposed use is adequate in size and shape to accommodate the proposed use.

Finding 2: That the site for the proposed use relates to streets and highways adequate in width and pavement type to carry the quantity and kind of traffic generated by the proposed use.

		Existing Conditions	Proposed Operation
Private Road	No	N/A	N/A
Public Road Frontage	Yes	Mt. Whitney and Feland Avenue	No change
Direct Access to Public Road	Yes	Mt. Whitney Avenue - Good Condition	No change
Road Classification		Mt. Whitney Avenue is classified as an Arterial Road. Belmont Avenue is classified as a Local Road.	No change
Road Width		Mt Whitney Avenue has an existing right-of-way of 60 feet with a recommended right-of-way of 106 feet per the Fresno County General Plan. Feland Avenue has an existing right-of-way of 60 feet with a recommendation of 60 feet per the Fresno County General Plan.	23 feet of additional right-of-way across the parcel frontage on West Mt. Whitney Avenue will be dedicated.
Road Surface		Asphalt concrete	No change
Traffic Trips		Based on event	N/A
Traffic Impact Study (TIS) Prepared	No	N/A	N/A
Road Improvements Required	No	Mt. Whitney and Feland Avenues – Good condition	N/A

Reviewing Agency/Department Comments Regarding Adequacy of Streets and Highways:

Road Maintenance and Operation:

All conditions & comments on previous applications still apply if not already in place.

The existing fence along with any other existing improvements shall be relocated out of the County of Fresno’s right-of-way.

The proposed stop sign located at the driveway cannot be placed within County’s right-of-way. This sign shall be placed within the property lines.

The access point to Mount Whitney Ave shall be kept clear from any obstructions for visibility purposes with a 20 foot X 20 foot corner cutoff. Fences, walls, and hedges shall not exceed three (3) feet in height. Any branches of trees, signs, etc. located within the corner cut-off area must be trimmed and/or maintained at a height of not less than eight (8) feet.

The above comments are regulatory requirements and will be noted under the project notes section. No other comments specific to the adequacy of the site were expressed by reviewing Agencies or Departments.

Finding 2 Analysis:

No reviewing County agency expressed concerns regarding impacts on County-maintained roads. Direct access to the site is provided off Mt. Whitney Avenue and the applicant will dedicate 23 feet of additional right-of-way across the parcel frontage on Mt. Whitney. Based on the existing nature and similar proposed use, staff believes that the roads to service the operation at the project site will remain adequate to accommodate the proposed use.

Recommended Conditions of Approval:

The applicant shall provide the County with an irrevocable offer of dedication for 23 feet of additional road right-of-way across the parcel frontage on Mt. Whitney Ave

Finding 2 Conclusion:

Finding 2 can be made based as the above information did not identify any deficiencies.

Finding 3: That the proposed use will have no adverse effect on abutting property and surrounding neighborhood or the permitted use thereof.

	Size:	Use:	Zoning:	Nearest Residence:
North	25 acres	Public School	AL-20	60 feet
South	6 acres	Church	R-1	50 feet
East	0.32 acres	Single Family Residence	R-1B	500 feet
West	1.22 acres	Commercial	C-M	800 feet

Reviewing Agency/Department Comments:

Environmental Health Division:

The potential adverse impacts caused by this project could include (but are not limited to) water quality degradation, odors, noise and vectors.

Environmental Health Division provided comments stating potential adverse effects regarding water quality degradation, odors, noise and vectors, which are addressed by regulatory procedures within The State of California Health and Safety Code, Code of Regulations, and Plumbing and Building Codes.

No other comments specific to potential impacts on the surrounding neighborhood were expressed by reviewing Agencies or Departments.

Finding 3 Analysis:

Environmental Health Division noted that the project would have potential adverse effect, however regulatory compliance with The State of California Health and Safety Code, Code of Regulations, and Plumbing and Building Codes would be followed to avoid impact.

Recommended Conditions of Approval:

Development shall be in accordance with the approved site plan.

Finding 3 Conclusion:

Finding 3 can be made with adherence to the regulatory procedures above, that the proposed onsite parking and driveway will have less than significant impact on the aesthetics of the surrounding properties.

Finding 4: That the proposed development is consistent with the General Plan.

Reviewing Agency/Department Comments:

Policy Planning:

The subject parcels are designated as Residential in the County General Plan.

There are no General Plan issues with the proposed CUP.

No other comments specific to General Plan Policy were expressed by reviewing Agencies or Departments.

Finding 4 Analysis:

The Policy Planning Division of the Department of Public Works indicated that the proposed project does not conflict with the Fresno County General Plan.

Recommended Conditions of Approval:

None.

Finding 4 Conclusion:

Finding 4 can be made as there is no General Plan issues with the proposed Unclassified Conditional Use Permit.

Finding 5: That the conditions stated in the resolution are deemed necessary to protect the public health, safety and general welfare.

Analysis Finding 5:

The proposed conditions of approval were developed based on studies and consultation with specifically qualified staff, consultants, and outside agencies. They were developed to address the specific impacts of the proposed project and were designed to address the public health, safety, and welfare. Additional comments and project notes have been included to assist in identifying existing non-discretionary regulations that also apply to the project. The Applicant has signed an acknowledgement agreeing to the proposed mitigation measures and has not advised staff of any specific objection to the proposed conditions of approval.

Finding 5 Conclusion:

Finding 5 can be made based on staff's analysis. The conditions stated in the resolution are deemed necessary to protect the public health, safety, and general welfare.

PUBLIC COMMENT:

No public comment was received as of the date of preparation of this report.

SUMMARY CONCLUSION:

Staff believes that the proposed increase onsite parking does not increase traffic or present any adverse impacts and is consistent with the Fresno County General Plan.

SUMMARY RECOMMENDATION:

Based on the factors cited in the analysis, all the required Findings for granting the Unclassified Conditional Use Permit can be made. Staff therefore recommends approval of Unclassified Conditional Use Permit No. 3747, subject to the Conditions of Approval and Project Notes.

PLANNING COMMISSION MOTIONS:

Recommended Motion (Approval Action)

- Move to determine the required Findings can be made and move to approve Unclassified Conditional Use Permit No. 3747, subject to the Conditions of Approval and Project Notes listed in Exhibit 1; and
- Direct the Secretary to prepare a Resolution documenting the Commission's action.

Alternative Motion (Denial Action)

- Move to determine that the required Findings cannot be made (state basis for not making each of the Findings) and move to deny Unclassified Conditional Use Permit No. 3747; and
- Direct the Secretary to prepare a Resolution documenting the Commission's action.

Recommended Conditions of Approval and Project Notes:

See attached Exhibit 1.

**Conditional Use Permit Application No. 3747
Conditions of Approval and Project Notes**

Conditions of Approval	
1.	Development shall be in accordance with the approved site plan.
2.	The applicant shall provide the County with an irrevocable offer of dedication for 23 feet of additional road right-of-way across the parcel frontage on Mt. Whitney Ave
Notes	
The following Notes reference mandatory requirements of Fresno County or other Agencies and are provided as information to the project Applicant.	
1.	<p>The Fresno County Environmental Health Division provides the following:</p> <ul style="list-style-type: none"> a. If any underground storage tank(s) are found during construction, the applicant shall apply for and secure an Underground Storage Tank Removal Permit from the Fresno County Department of Public Health, Environmental Health Division. Contact the Fresno County Hazmat Compliance Program at (559) 600-3271 for more information.
2.	<p>The Fresno County Road Maintenance and Operations Division provide the following comments:</p> <ul style="list-style-type: none"> a. All conditions & comments on previous applications still apply if not already in place. b. The existing fence along with any other existing improvements shall be relocated out of the County of Fresno's right-of-way. c. The proposed stop sign located at the driveway cannot be placed within County's right-of-way. This sign shall be placed within the property lines. d. The access point to Mount Whitney Ave shall be kept clear from any obstructions for visibility purposes with a 20 foot X 20 foot corner cutoff. Fences, walls, and hedges shall not exceed three (3) feet in height. Any branches of trees, signs, etc. located within the corner cut-off area must be trimmed and/or maintained at a height of not less than eight (8) feet.
3.	<p>The Fresno County Development Engineer provides the following comments:</p> <ul style="list-style-type: none"> a. All Conditions of Approval for any previous applications shall be implemented if not already in place. b. Refer to Road Maintenance & Operations Division, Road Operations for comments on Mt. Whitney Avenue and Feland Avenue.

- c. According to FEMA FIRM Panel 2900J, the parcels are not subject to flooding from the 100-year storm.
- d. Any additional storm water runoff generated by the proposed development of this site cannot be drained across property lines or into the County road right-of-way, and must be retained on-site, per County Standards.
- e. An engineered grading and drainage plan is required to show how the additional storm water runoff generated by the proposed development will be handled without adversely impacting adjacent properties. The grading and drainage plan should provide calculations of the proposed ponding basin storage capacity and the basin design storage capacity for verification purposes.
- f. Any proposed landscape areas of 500 sq. ft. or more will be subject to the Model Water Efficient Landscape Ordinance (MWELo) and MWELo form/s and/or separate landscape and irrigation design plan should be required.
- g. A Notice of Intent (NOI) and Storm Water Pollution Prevention Plan (SWPPP) are required to be filed with State Water Resources Control Board (SWRCB) before the commencement of any construction activities disturbing 1.0 acre or more of area. Copies of completed NOI with WDID # and SWPPP shall be provided to Development Engineering prior to any grading work.
- h. Any existing or proposed parking areas should comply with the Fresno County Off-Street Parking Design Standards. Stalls should be 18 foot x 9 foot, and backing distance must be a minimum of 29 foot for 90-degree parking stalls. Also 5 foot should be provided beyond the last stall in any row to provide for backing. Any proposed handicap accessible parking stalls and curb ramps shall be in compliance with ADA standards and the maximum surface slope within the disabled parking space(s) and adjacent access aisle(s) shall not exceed 2% in any direction.
- i. The end of curbed/taper edge of any existing or proposed access driveway approach should be set back a minimum of 5 foot from the property line.
- j. Any existing or proposed entrance gate should be set back a minimum of 20 foot from the road right-of-way line or the length of the longest truck entering the site, and shall not swing outward.
- k. For unpaved or gravel surface access roads, the first 100 feet off of the edge of the road right-of-way must be graded and asphalt concrete paved or treated with dust palliative.
- l. If not already present, a 10 foot x 10 foot corner cut-off should be improved for sight distance purposes at any existing or proposed driveway accessing Mt. Whitney Avenue or Feland Avenue
- m. Any work done within the County road right-of-way to construct a new driveway or improve an existing driveway will require an Encroachment Permit from the Road Maintenance and Operations Division.
- n. A grading permit is required for any grading proposed with this application.

LOCATION MAP



UCUP 3747

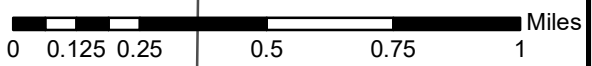
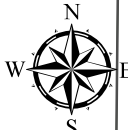
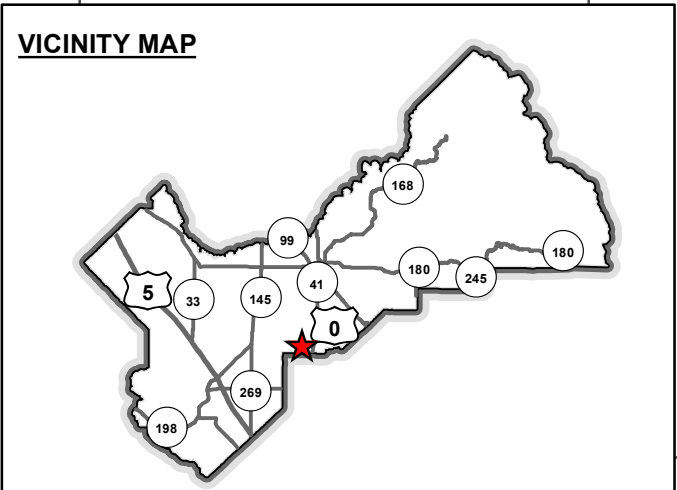
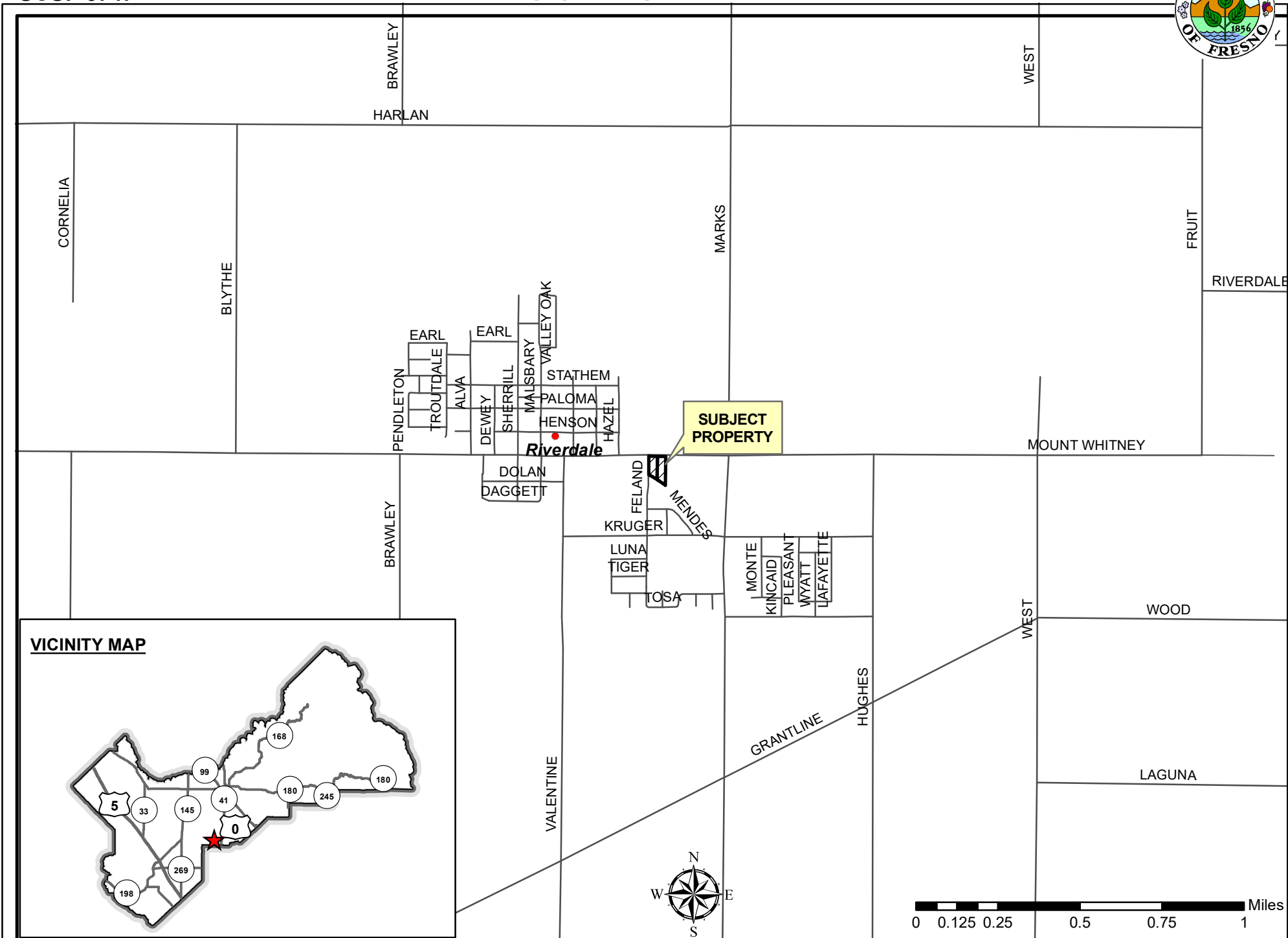

EXHIBIT 2

EXISTING ZONING MAP

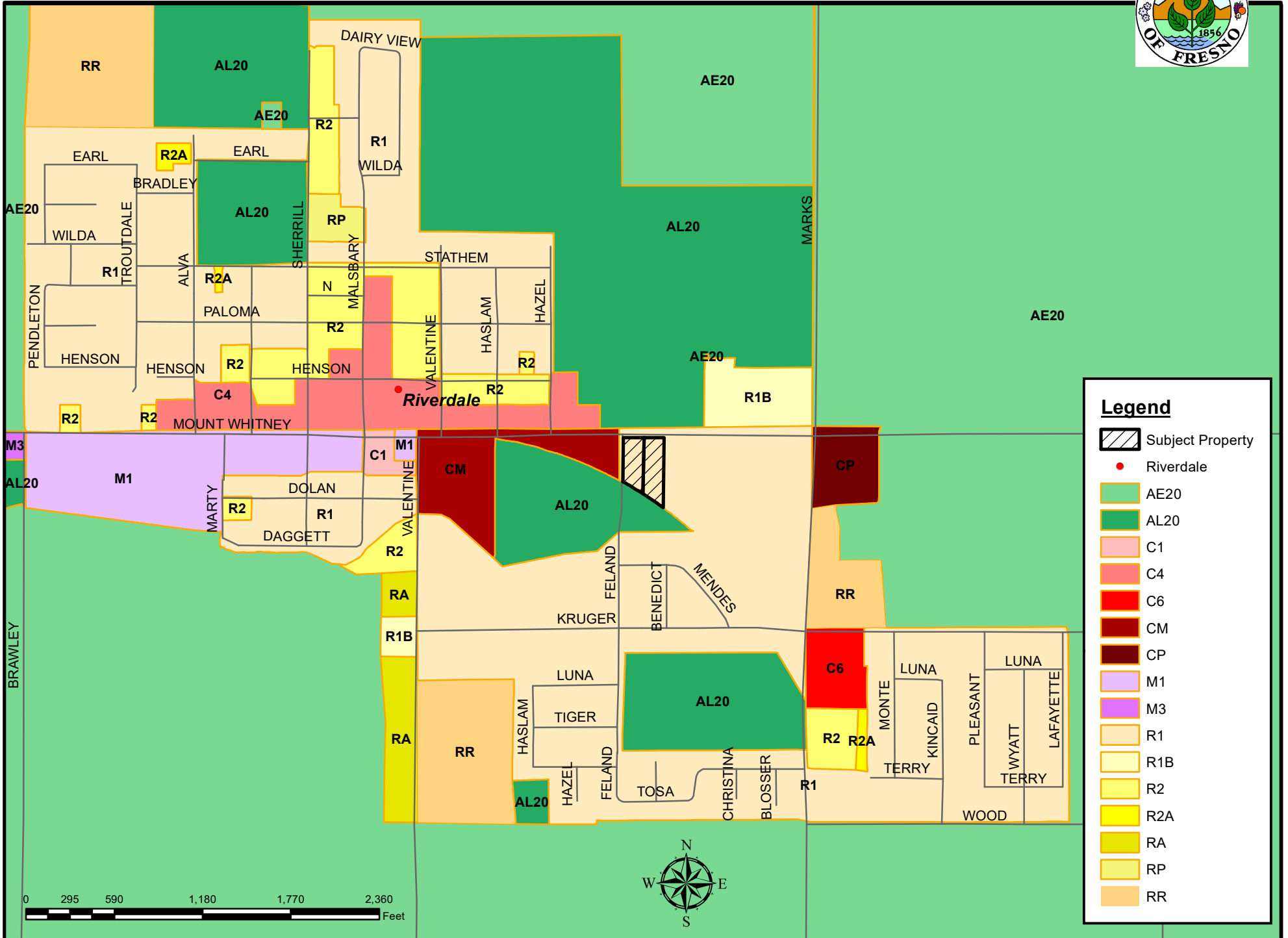
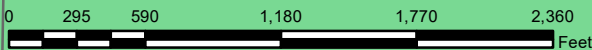
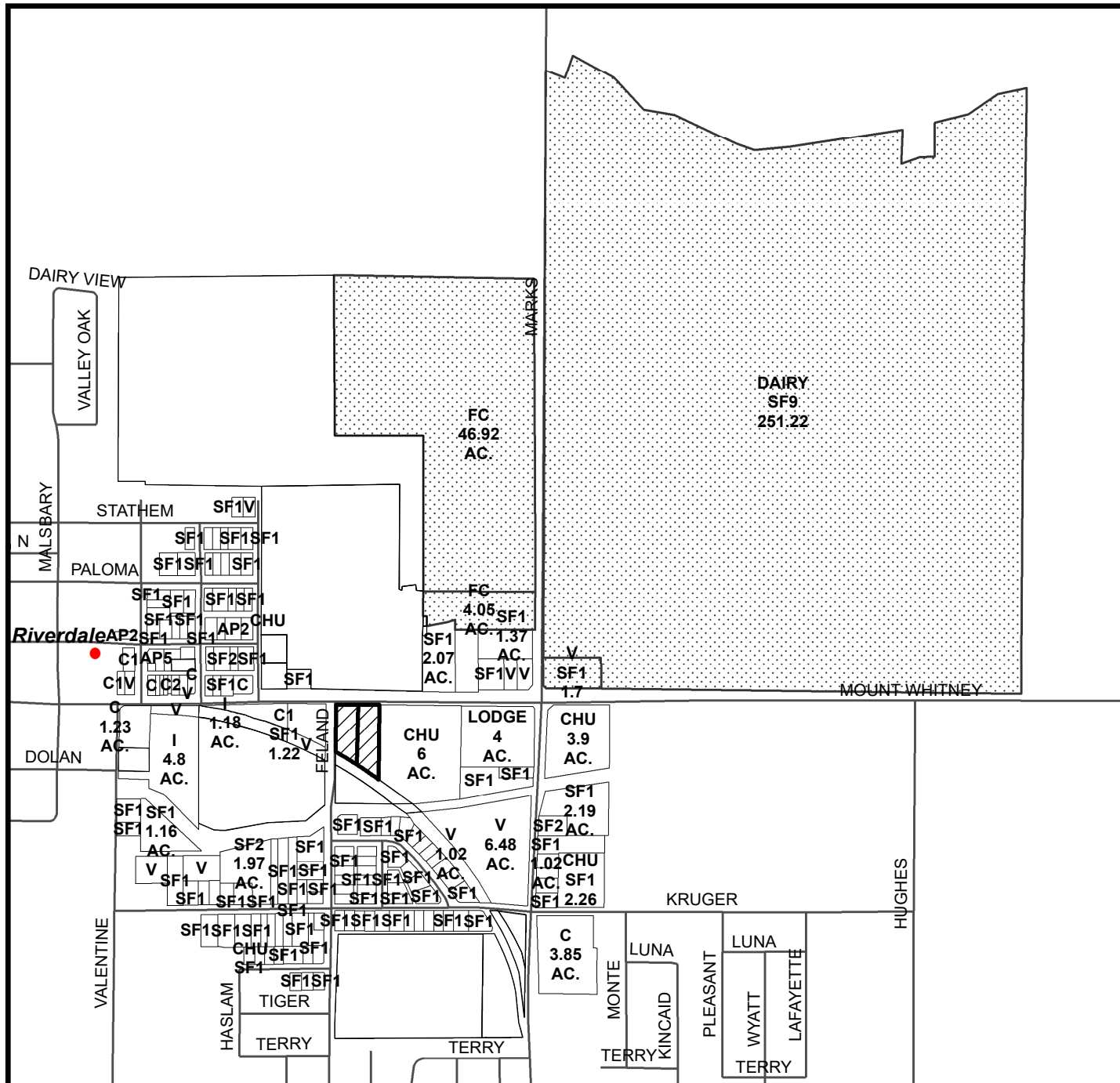

EXHIBIT 3



EXISTING LAND USE MAP

UCUP 3747



LEGEND	
AP1 - APARTMENT	
C - COMMERCIAL	
C# - COMMERCIAL	
CHU - CHURCH	
DAIRY	
FC - FIELD CROP	
I - INDUSTRIAL	
LODGE	
SF# - SINGLE FAMILY RESIDENCE	
V - VACANT	

LEGEND:

- Subject Property
- Ag Contract Land
- Riverdale

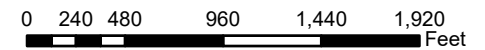
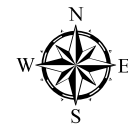

Department of Public Works and Planning
Development Services Division

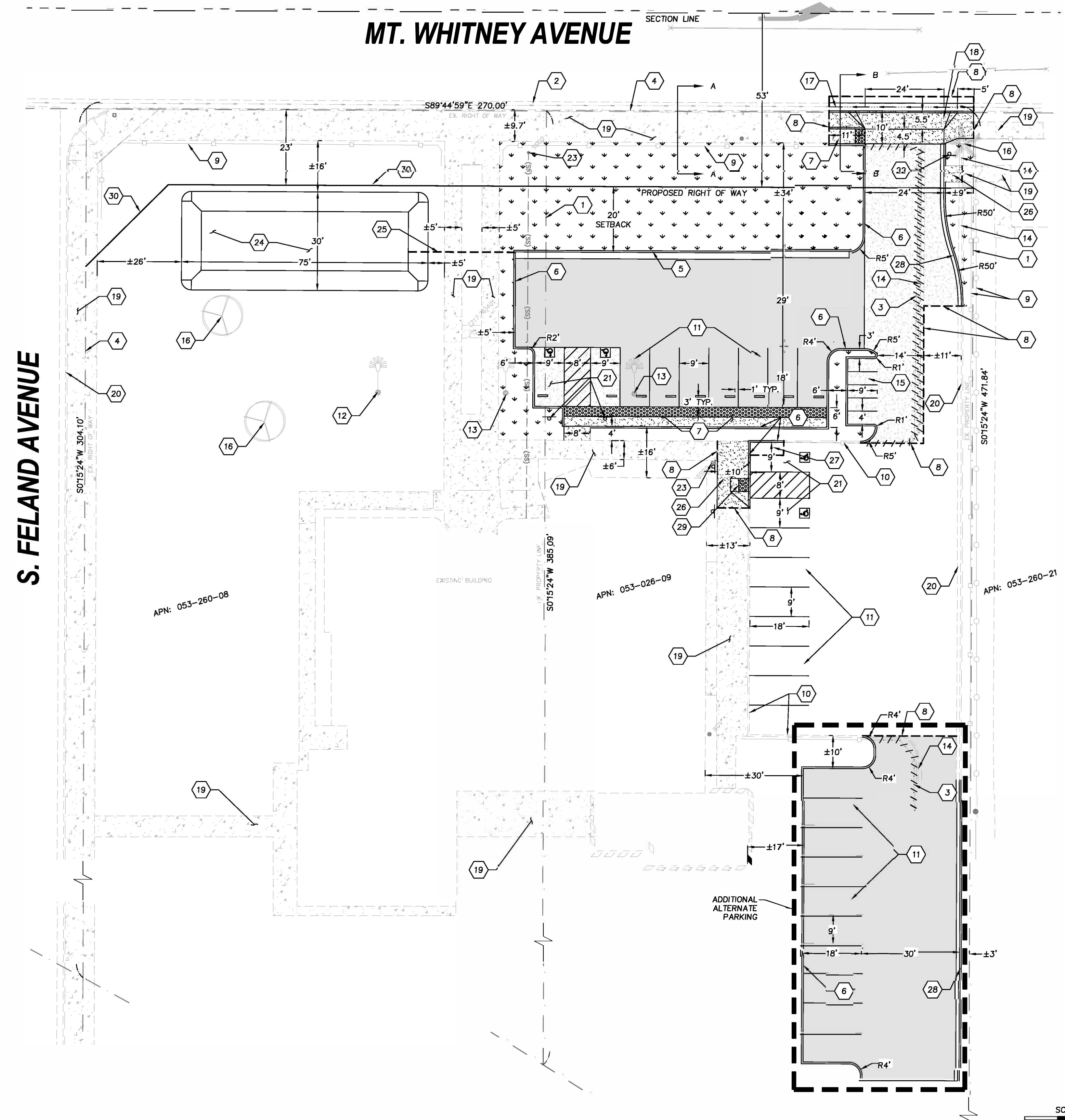

SITE PLAN KEYNOTES:

- 1 EXISTING PROPERTY LINE
- 2 EXISTING VALLEY GUTTER TO REMAIN
- 3 EXISTING FENCE TO BE REMOVED
- 4 EXISTING RIGHT OF WAY
- 5 PROPOSED CURB AND GUTTER PER DETAIL D2/2
- 6 PROPOSED 6" CURB PER DETAIL D1/2
- 7 PROPOSED MODIFIED ACCESSIBLE CURB RAMP PER DETAIL D3/2
- 8 SAWCUT LIMIT
- 9 EXISTING FENCE TO REMAIN
- 10 EXISTING CURB TO REMAIN
- 11 PROPOSED PARKING STALLS
- 12 EXISTING SITE LIGHTING TO REMAIN
- 13 EXISTING SITE LIGHTING TO BE REMOVED
- 14 EXISTING CURB AND GUTTER TO BE REMOVED
- 15 PROPOSED MOTOR BIKE PARKING STALLS
- 16 EXISTING TREE TO BE REMAIN
- 17 PROPOSED VALLEY GUTTER PER DETAIL D5/2
- 18 PROPOSED 24' DRIVE APPROACH PER FRESNO COUNTY STD. DWG. D-3
- 19 EXISTING SIDE WALK TO REMAIN
- 20 EXISTING CURB & GUTTER TO REMAIN
- 21 PROPOSED ACCESSIBLE PARKING AND SIGN PER DETAIL D7/2 & D10/2
- 22 PROPOSED STOP SIGN (TYP)
- 23 EXISTING SEWER CLEANOUT TO REMAIN
- 24 PROPOSED 18" OR LESS DEEP STORM WATER RETENTION BASIN
- 25 PROPOSED STORM DRAIN TUBE
- 26 PROPOSED SIDEWALK PER DETAIL D11/2
- 27 EXISTING RAMP TO BE REMOVED
- 28 PROPOSED CURB & 12" GUTTER PER DETAIL D6/2
- 29 PROPOSED CURB RAMP PER DETAIL D6/2
- 30 PROPOSED RIGHT OF WAY

PAVEMENT TABLE:

	LANDSCAPE
	A.C. PARKING PAVING
	CONCRETE PAVING
	CONCRETE SIDEWALK AND DRIVE APPROACH

LEGEND:

- EXISTING SECTION LINE
- EXISTING CENTER LINE
- EXISTING PROPERTY LINE
- EXISTING RIGHT-OF-WAY LINE
- EXISTING CURB & GUTTER
- EXISTING AC DIKE
- EXISTING EDGE OF PAVEMENT
- EXISTING SWALE
- EXISTING WALL
- EXISTING FIRE HYDRANT
- EXISTING SIGN
- EXISTING STORM DRAIN MANHOLE
- EXISTING TREE
- EXISTING UTILITY POLE
- EXISTING WATER VALVE
- PROPOSED SIGN

BASIS OF BEARING:

THE GEODETIC OBSERVATION OF THE NORTH LINE OF THE NORTHEAST QUARTER OF SECTION 25, TOWNSHIP 17 SOUTH, RANGE 19 EAST, MOUNT DIABLO BASE AND MERIDIAN, TAKING TO BE NORTH 89°44'59" WEST.

BASIS OF ELEVATIONS:

USGS BENCH MARK "X 669 RESE" FOUND USGS BRASCON MONUMENT STAMPED "X 669 RESET 1984".
TAKEN AS 220.6 FEET NGVD 29

VICINITY MAP

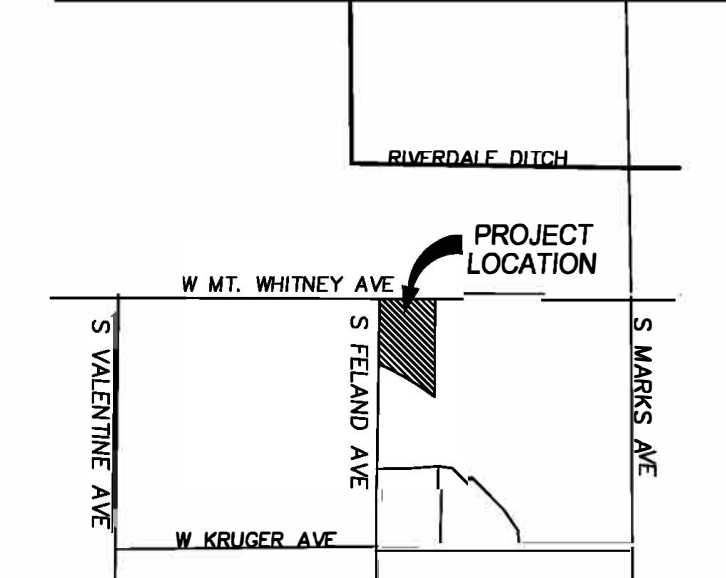

PARKING LOT INFORMATION

PARKING SPACES PROVIDED:		ALTERNATE PARKING:
STANDARD (9x18):	14	STANDARD (9x18):
ADA (9x18):	4	MOTOR BIKE (4x9):
MOTOR BIKE (4x9):	5	TOTAL:
TOTAL:	23	

SITE PLAN INFORMATION

PROJECT SITE AREA: ±0.39 AC.
(P) PAVED AREA: ±6,345 S.F.
(P) LANDSCAPE AREA: ±5,062 S.F.

PROPERTY INFORMATION

ADDRESS: 3085 W. MT. WHITNEY AVENUE, RIVERDALE CA 93656

APN: 053-260-08
053-260-09

OWNER'S INFORMATION

NAME: RIVERDALE MEMORIAL DISTRICT
ADDRESS: 3085 W. MT. WHITNEY AVENUE RIVERDALE CA 93656

HANDICAP ACCESSIBILITY NOTES:

- THERE SHALL BE NO VERTICAL OFFSET ALONG A PATH OF TRAVEL INTO THE BUILDING OR RESTROOMS GREATER THAN 1/2 INCH.
- PROVIDE ACCESSIBLE PARKING WITH PROPER SIGNS AND SYMBOLS. AT LEAST ONE STALL WITH AN EIGHT FOOT UNLOADING AREA SHALL BE PROVIDED AND DESIGNATED FOR VANS.
- ALL STALLS SHALL BE MARKED WITH THE INTERNATIONAL SYMBOL OF SPACES AND A WARNING THAT VEHICLES IN VIOLATION OF SECTION 10-1017 OF THE MUNICIPAL CODE SHALL BE TOWED AWAY. THE INTERNATIONAL SYMBOL AND TOW-AWAY WARNING SHALL BE POSTED CONSPICUOUSLY ON 7-10 FOOT POLES.
- ALL HANDICAP PARKING STALLS SHALL BE PLACED ADJACENT TO FACILITY ACCESS RAMPS OR IN STRATEGIC AREAS WHERE THE HANDICAP SHALL NOT HAVE TO WHEEL OR WALK BEHIND PARKED VEHICLES WHILE TRAVELING TO OR FROM HANDICAP PARKING STALLS AND RAMPS.
- PROVIDE THE FOLLOWING INFORMATION FOR HANDICAP PARKING.
 - APPROVED SIGN TO BE POSTED IN CONSPICUOUS PLACE AT EACH ENTRANCE TO THE OFF-STREET PARKING FACILITY WHICH DISPLAYS INFORMATION FOR HANDICAP PARKING
 - SURFACE SLOPE OF HANDICAP PARKING NOT TO EXCEED 1/4" PER FOOT GRADIENT IN ANY DIRECTION.
 - APPROVED INTERNATIONAL SYMBOL OUTSIDE AT PARKING STALL AND D.M.V. POSTING SIGN.

SITE NOTES:

- MINIMUM 2% SLOPE FOR A MINIMUM OF 5' FOR DRAINAGE AWAY FROM BUILDING.
- NO WATER SHALL DRAIN TO ADJACENT PROPERTY WITH NO ON-SITE WATER RETENTION.
- COMPACTION REPORT SHALL BE PREPARED BY AN APPROVED TESTING AGENCY UPON COMPLETION OF GRADING.
- ALL GRADING SHALL COMPLY WITH SECTION 7014-C OF THE 2013 CALIFORNIA BUILDING CODE.
- PROVIDE SOIL COMPACTION FROM AN APPROVED TESTING LAB FOR ALL AREAS WHERE LOOSE FILL IS USED OR WHERE BUILDING FOOTING WILL OCCUR.
- ANY SURVEY MONUMENTS WITHIN THE AREA OF CONSTRUCTION SHALL BE PRESERVED OR RESET BY A REG. CIVIL ENGINEER OR LICENSED LAND SURVEYOR.
- LIGHTING WHERE PROVIDED TO ILLUMINATE PARKING, SALES OR DISPLAY AREAS SHALL BE HOODED AND SO ARRANGED AND CONTROLLED SO AS NOT TO CAUSE A NUISANCE EITHER TO HIGHWAY TRAFFIC OR TO THE LIVING ENVIRONMENT. THE AMOUNT OF LIGHT SHALL BE PROVIDED ACCORDING TO THE STANDARDS OF THE DEPARTMENT OF PUBLIC WORKS.
- INSTALL STREET ADDRESS NUMERALS AT LEAST FOUR INCHES HIGH WITH MINIMUM 1/2-INCH STROKE MOUNTED ON A CONTRASTING BACKGROUND CLEARLY VISIBLE FROM THE STREET (CBC 501.2).
- A CHEMICAL TOILET IS REQUIRED TO BE ON-SITE DURING CONSTRUCTION.
- FINISH FLOOR ELEVATION TO BE 6" ABOVE THE CROWN OF THE STREET.
- DRIVEWAYS AND PRIVATE ROADS SHALL HAVE A MAXIMUM SLOPE OF 12% THE GRADE MAY BE INCREASED TO A MAXIMUM OF 20% FOR PAVED SURFACES.
- A SEPARATE PERMIT WILL BE REQUIRED FOR REVIEW OF THE FIRE AND LIFE SAFETY REQUIREMENTS INSIDE OF THE BUILDING WHICH INCLUDES BUT IS NOT LIMITED TO LIMITED TO STORAGE REQUIREMENTS

FIRE NOTES:

THIS PERMIT DOES NOT INCLUDE FIRE SPRINKLERS.
LAYOUT AND DETAILS OF THE FIRE SPRINKLER SYSTEM SHALL BE SUBMITTED TO AND APPROVED BY THE APPLICABLE FIRE MARSHAL PRIOR TO SUBMITTING TO FRESNO COUNTY FOR PERMIT INSTALLATION. ONE SET OF APPROVED PLANS SHALL BE MAINTAINED ON THE JOB SITE AND ONE SET RETAINED BY FRESNO COUNTY.

THE SPRINKLER SYSTEM SHALL BE INSTALLED, INSPECTED AND APPROVED BY THE FIRE MARSHAL PRIOR TO ISSUANCE OF OCCUPANCY PERMIT.
THIS PROJECT HAS BEEN DESIGNED WITH A UNIFORM LOAD OF POUNDS/SF TO SUPPORT THE FIRE SPRINKLER SYSTEM. ADDITIONALLY, WE HAVE DESIGNED THE MAIN SUPPORT MEMBERS (PURLINS, FRAMES, JOIST, ETC.) TO SUPPORT CONCENTRATED LOAD OF LARGER SPRINKLER LINES.
SIGNED _____
ENGINEER LIC. # _____

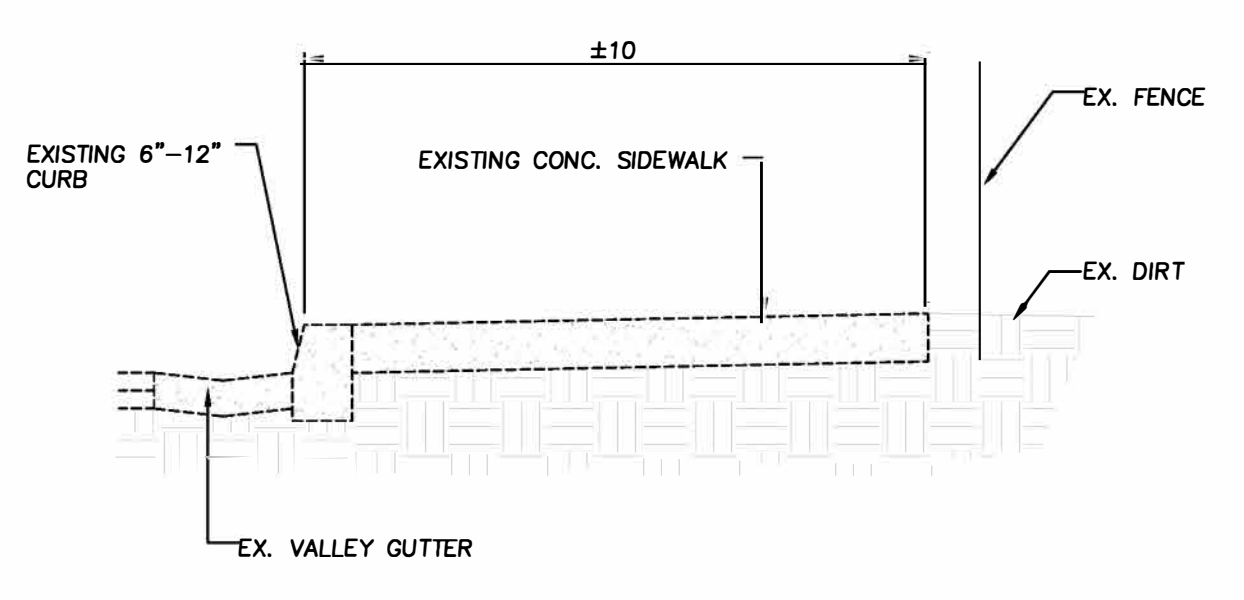

SECTION A-A
NO SCALE

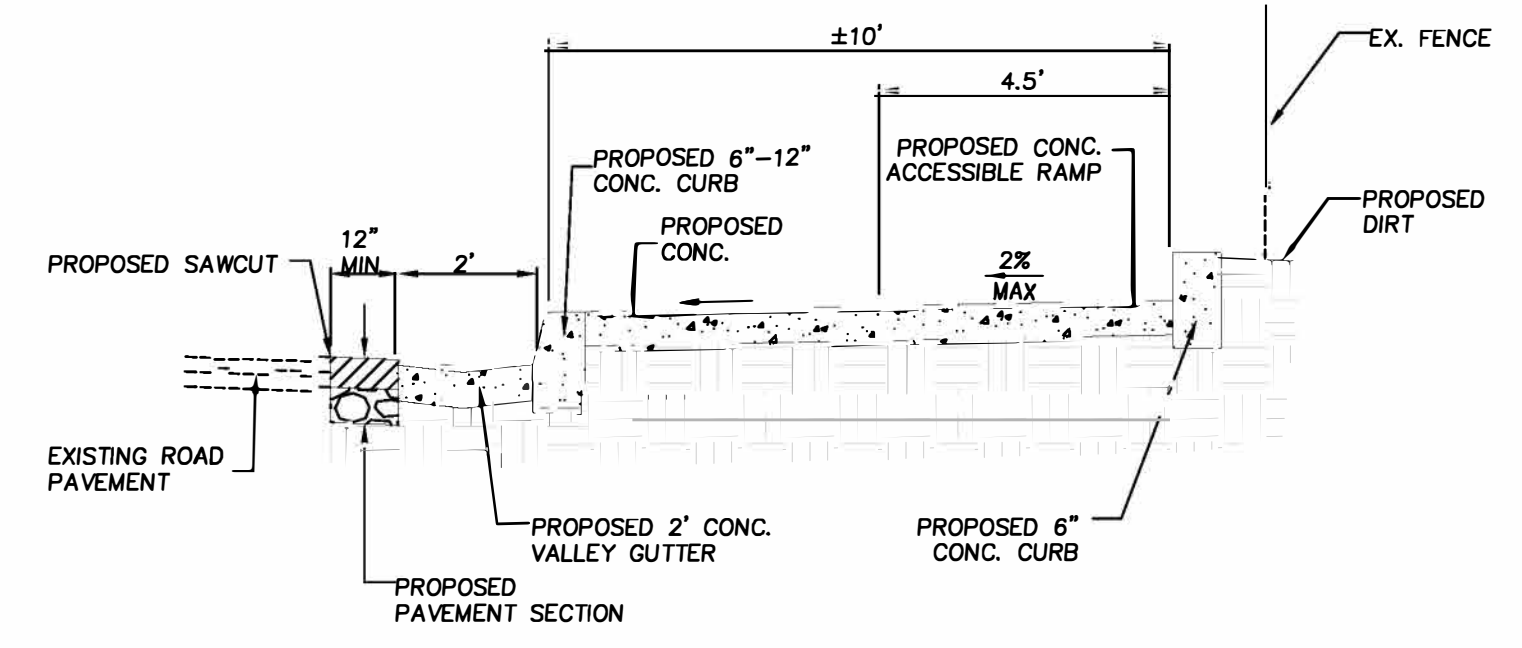

SECTION B-B
NO SCALE

Yamabe & Horn
Engineering, Inc.
CIVIL ENGINEERS • LAND SURVEYORS
2085 N. BURL AVENUE SUITE 101 FRESNO, CA 93727
TEL: (509) 344-5123 WEBSITE: YAMHOR.COM

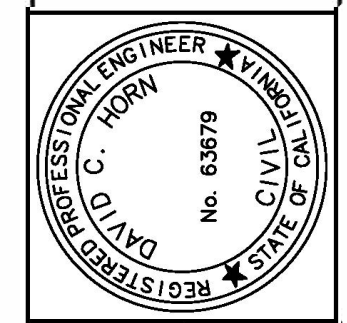
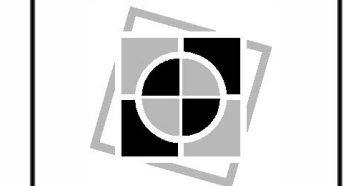

RMD ONSITE IMPROVEMENTS
PROPOSED SITE PLAN

PROJECT TITLE: RMD ONSITE IMPROVEMENTS
SHEET DESCRIPTION: PROPOSED SITE PLAN
Dr. By: EL
Ch. By: KR
Date: 04/22/2022
Scale: As Noted
YH Job No.: 21-316
Sheet No.: 1
of 2 Sheets

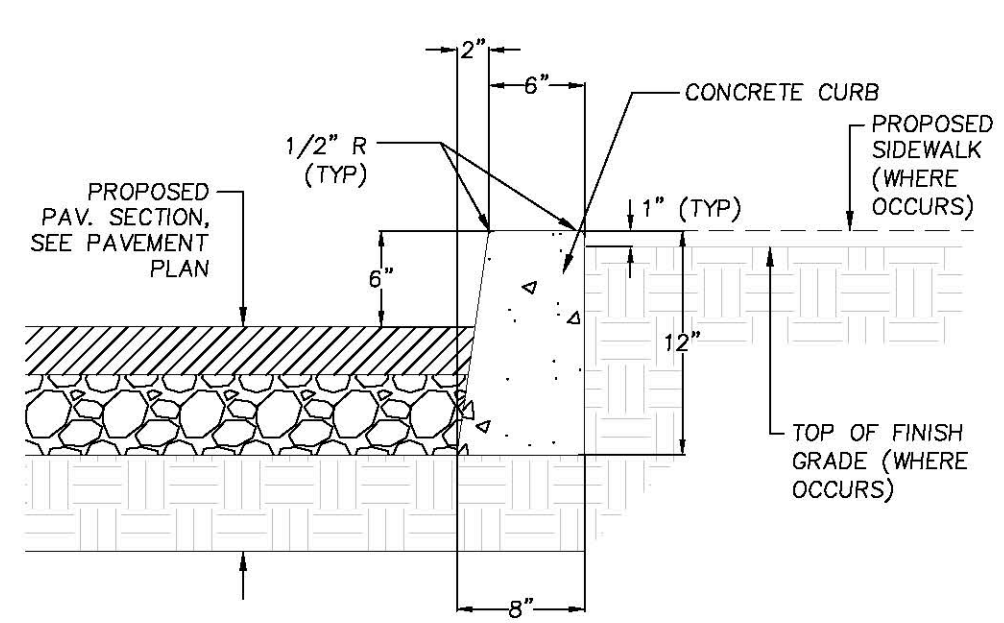
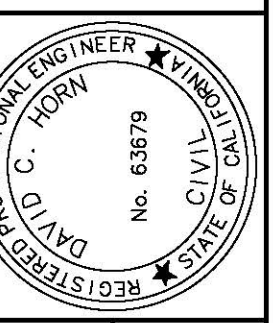
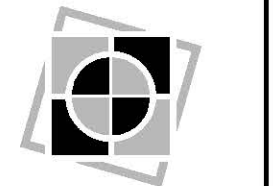

D1
6\"/>

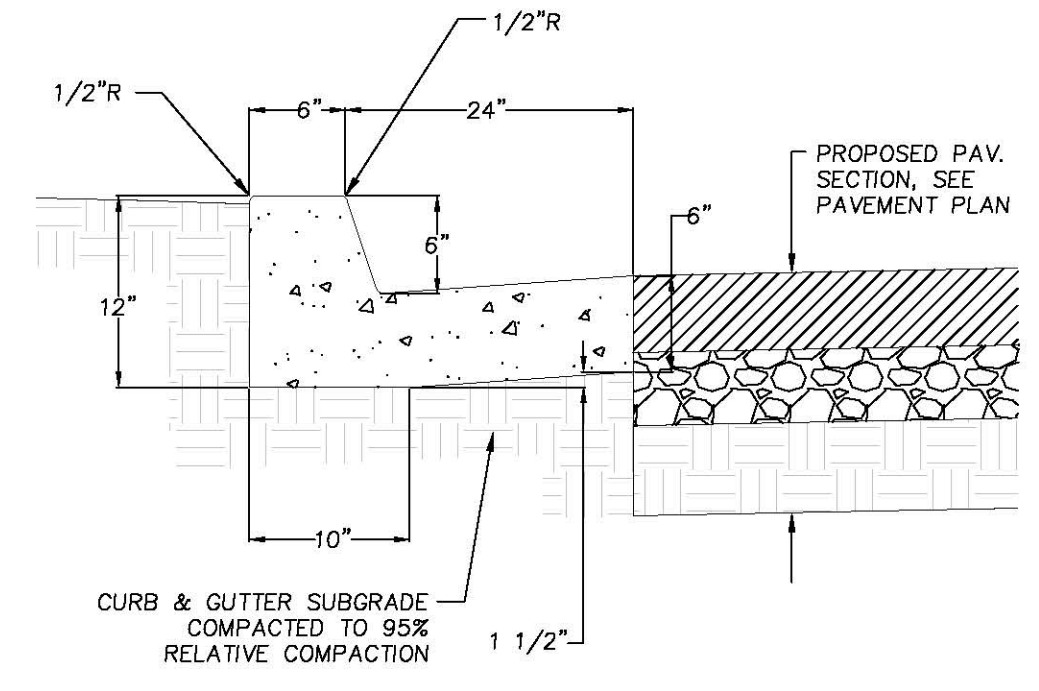

D2
CURB AND GUTTER DETAIL
 NO SCALE

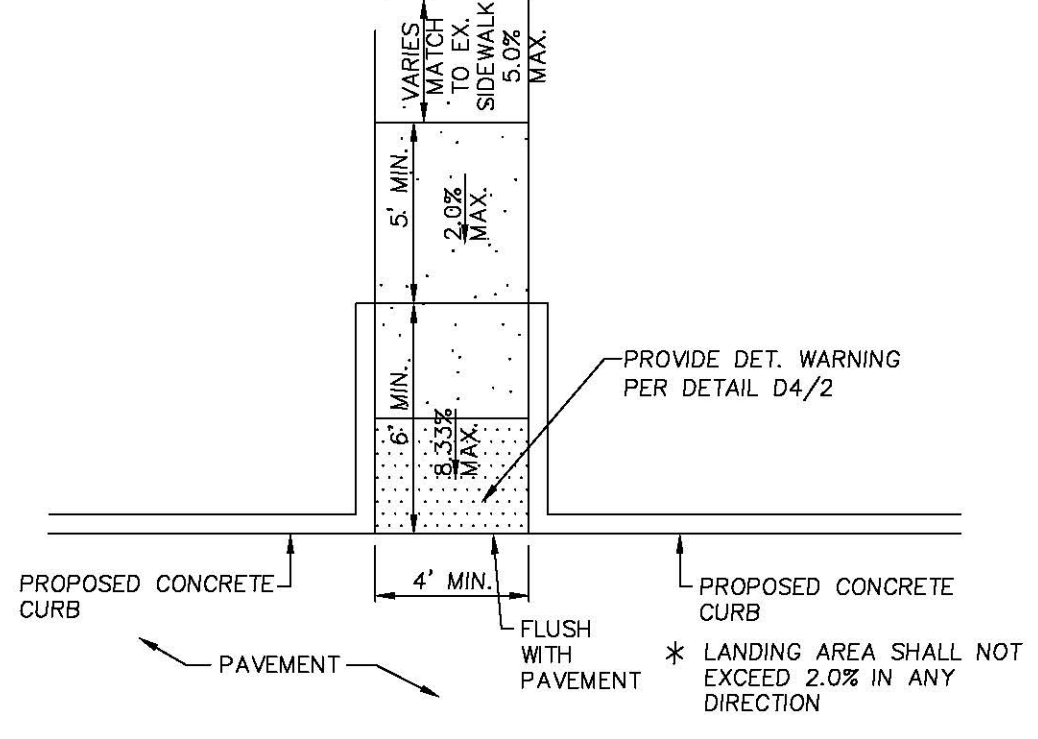

D3
MODIFIED ACCESSIBLE CURB RAMP DETAIL
 NO SCALE

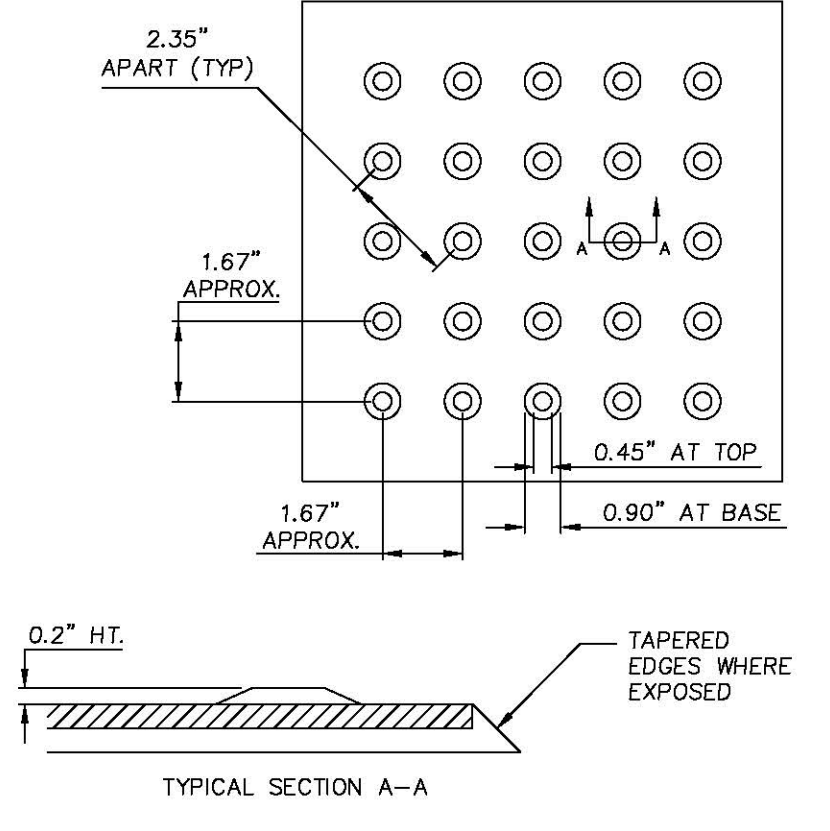

D4
TRUNCATED DOMES DETAIL
 NO SCALE

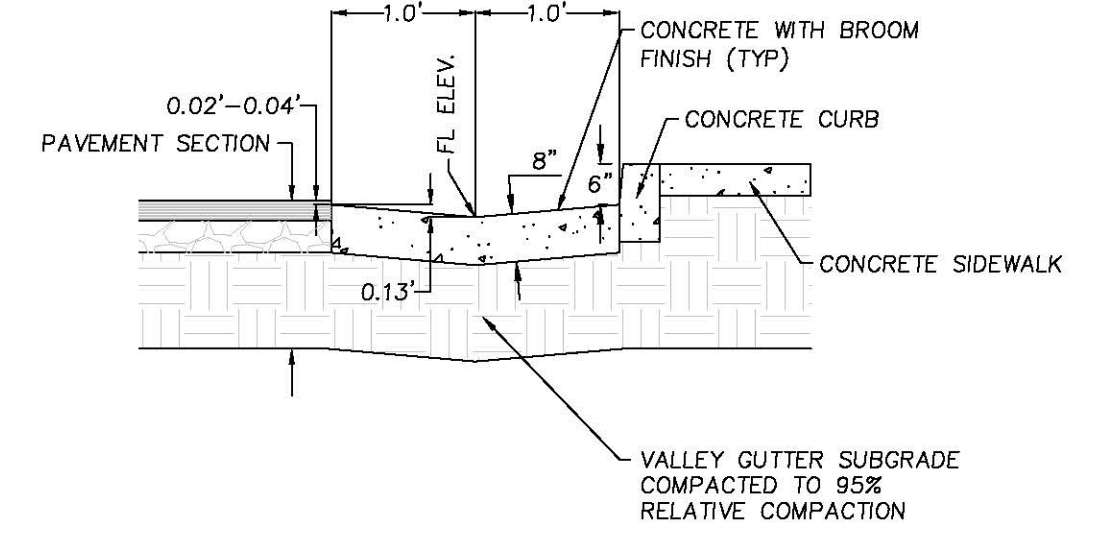

D5
2\"/>

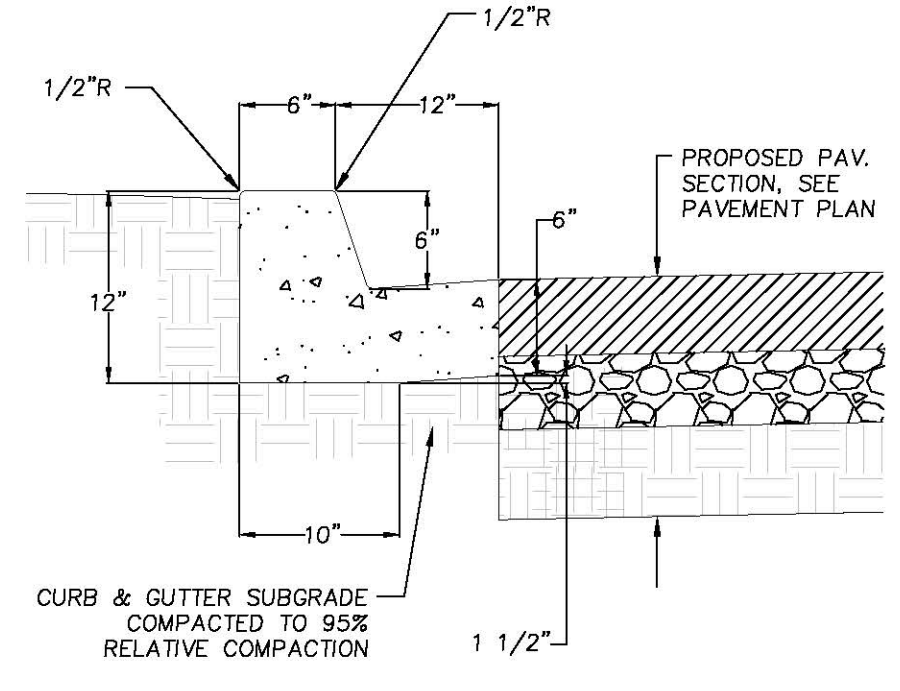

D6
CURB AND 12\"/>

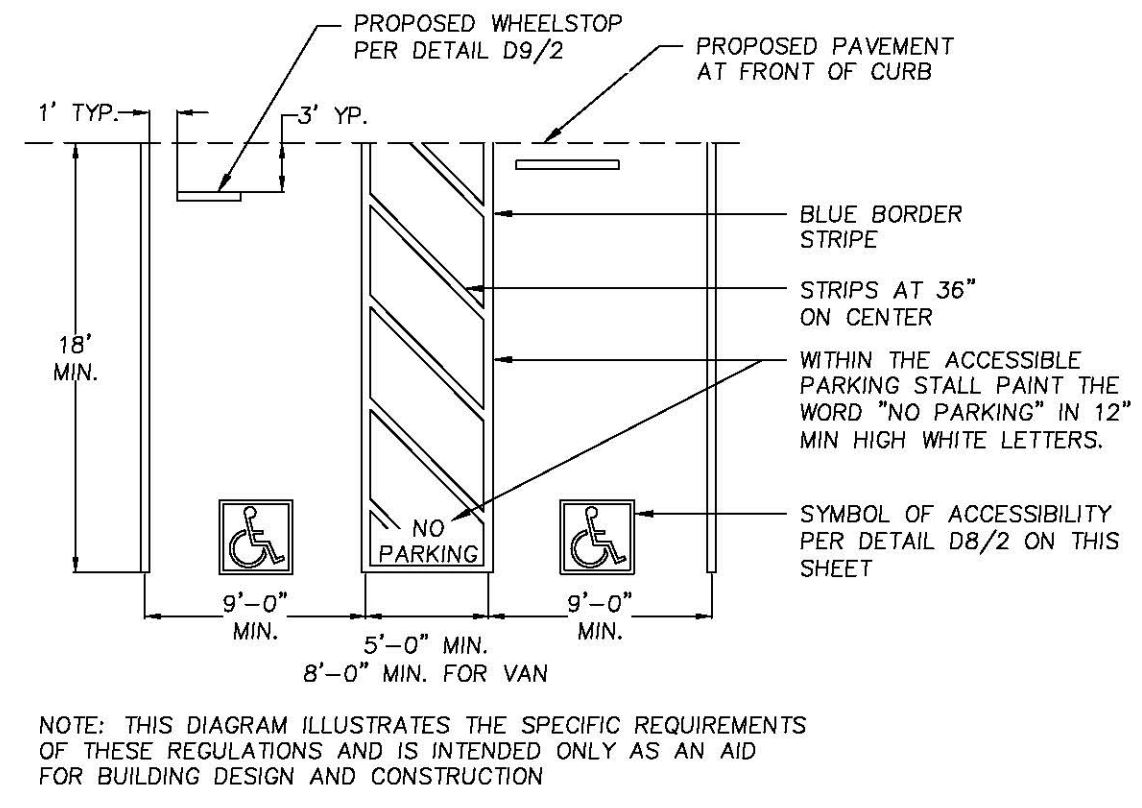

D7
ACCESSIBLE PARKING STALL
 NO SCALE

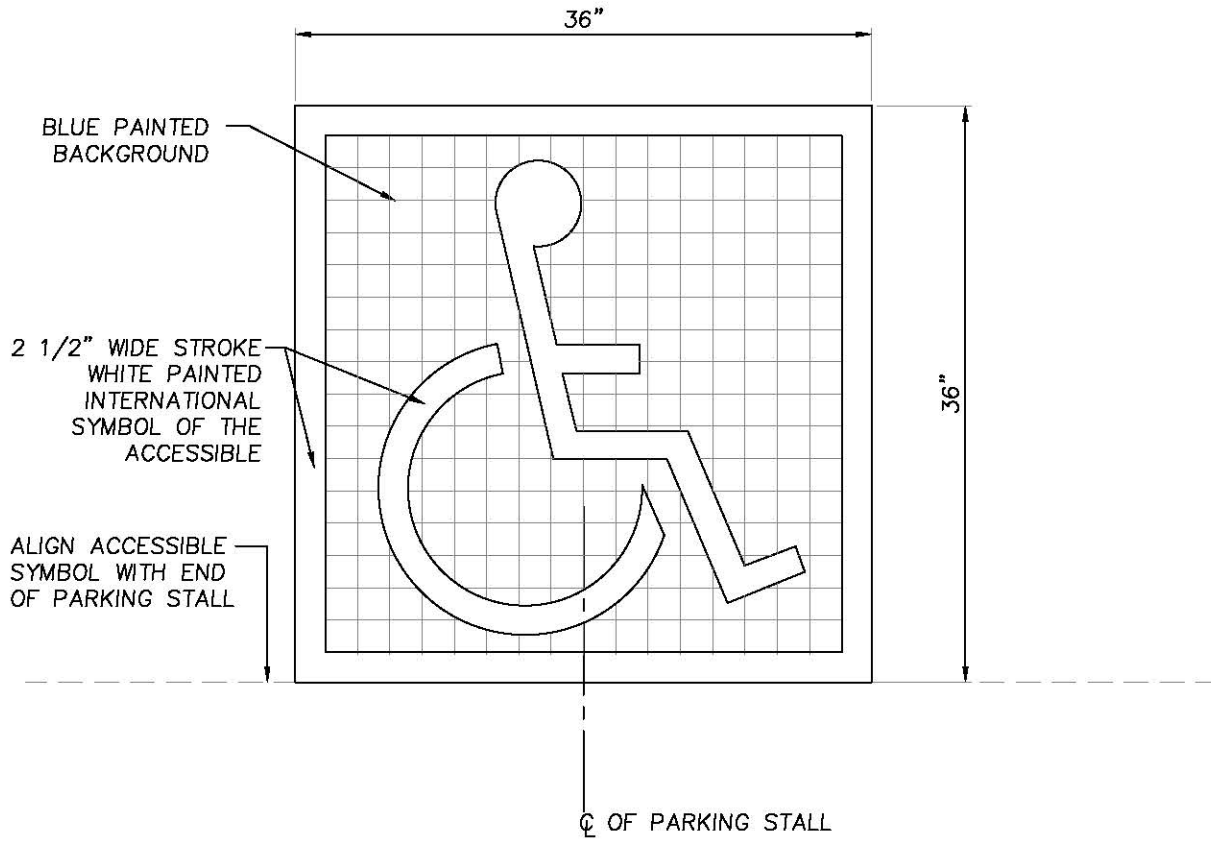

D8
ACCESSIBLE SURFACE IDENTIFICATION SYMBOL
 NO SCALE

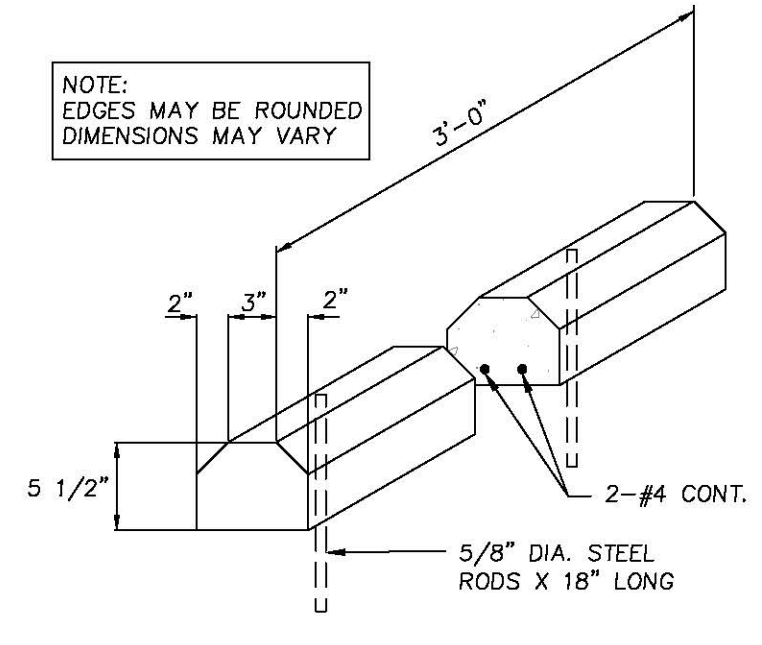

D9
CONCRETE WHEEL STOP
 NO SCALE

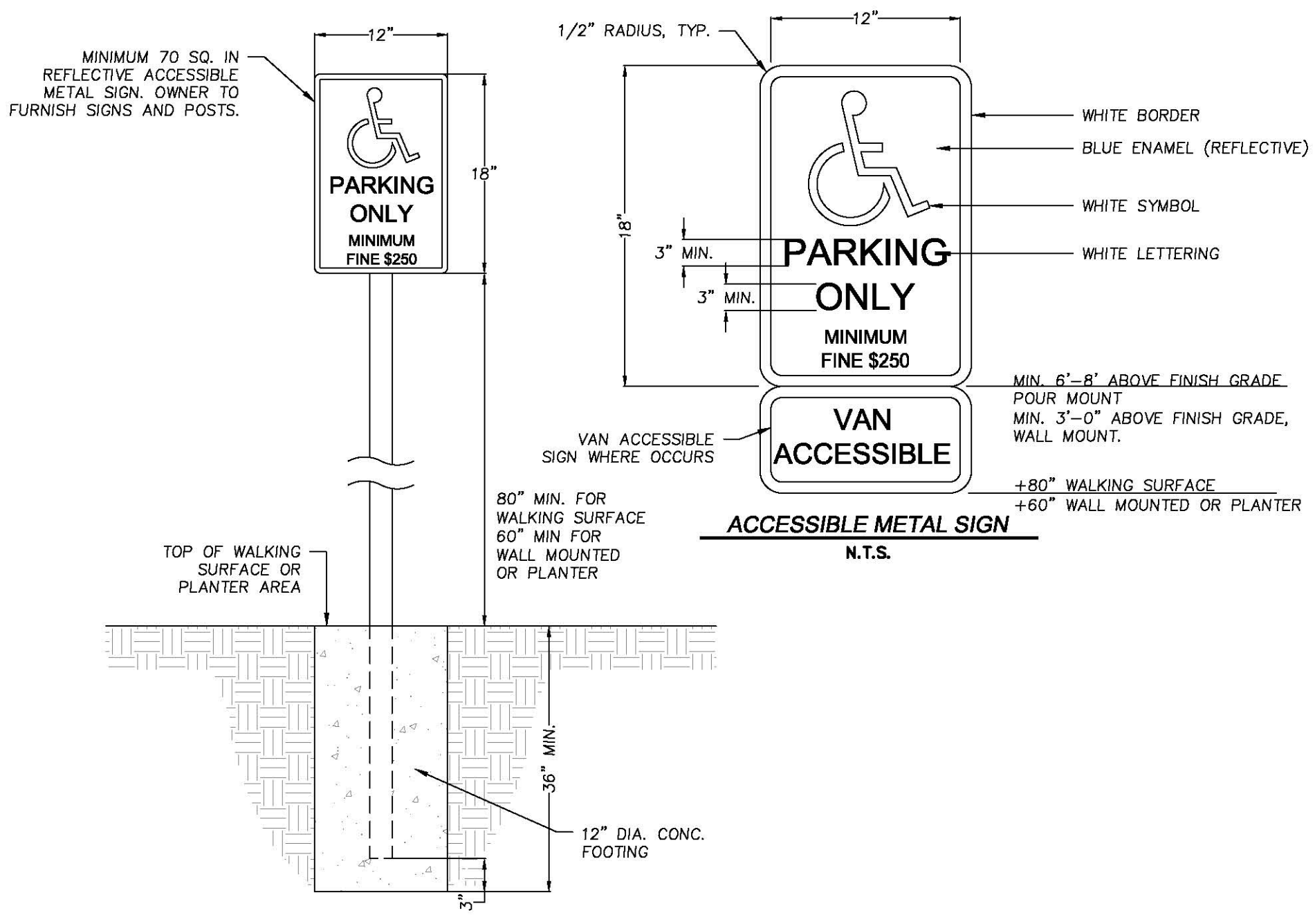

D10
SIGN AND POST INSTALLATION
 NO SCALE

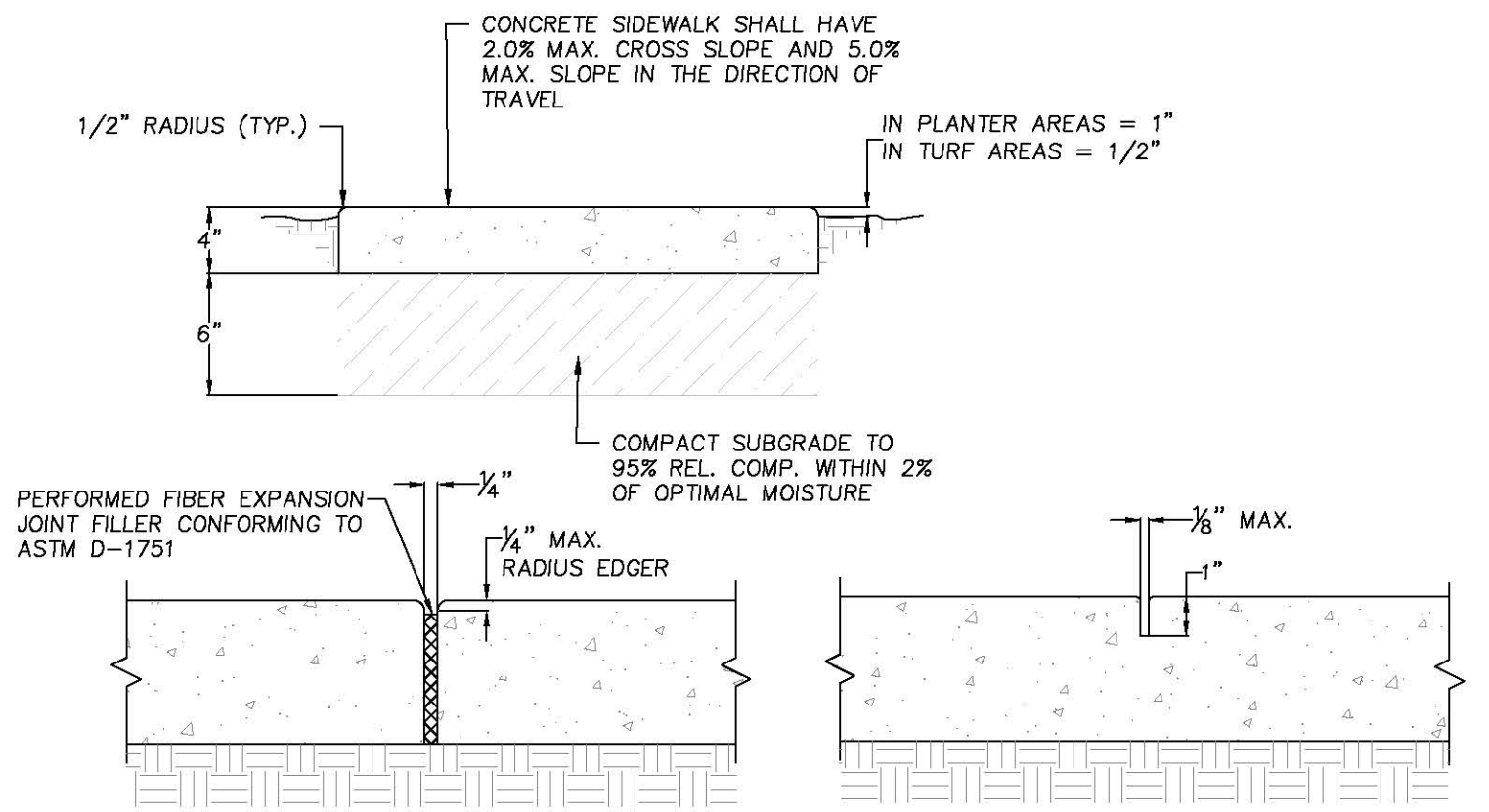

D11
SIDEWALK DETAIL
 NO SCALE

EXHIBIT 5 PAGE 2



September 15, 2022 (updated January 31, 2022, Op Statement)

To the County of Fresno
Department of Public Works and Planning
Development Services Division
2220 Tulare St. 6th Floor
Fresno, CA 93721

RE: Operational Statement for then Planning Submittal
Of Riverdale Memorial District-
Proposed Parking Additions
Application No.: SPR 8255 & CUP 3747

Project Description:

The proposed parking lot development is being submitted by Yamabe & Horn Engineering, Inc. on behalf of Riverdale Memorial District (RMD) and pertains to 2.45 acres. The property is located at 3085 West Mt. Whitney Avenue, Riverdale, CA 93656 - APN: 053-260-08, APN: 053-260-09 and is zoned as R1-Single Family Residential with similar planned use. The proposed development consists of the demolition of landscaping and the construction of a proposed parking lot and driveway of approximately 9,000 square feet. As a CBDG funded project, if adequate funding is available an additional alternative parking lot and driveway of approximately 4,600 square feet is also proposed.

The ultimate user(s) of this parking lot and site are typically used for meetings, community events, and private events. This hall does not have an operational time and is generally opened for scheduled events.

This site currently has two part time employees; however, we have provided 7 standard 9'x18' stalls and 2-ADA stalls for parking. In addition to the standard automotive parking, we are providing 5-4'x9' motorbike parking stalls. Furthermore, due to no visible striping in the existing parking lot, restriping of this lot is being proposed, adding 7 standard 9'x18' stalls and 2-ADA stalls for parking.

The Add. Alternate parking lot will provide an additional 10 standard 9'x18' stalls for parking and a drive aisle if sufficient funding is available. The proposed parking spaces and drive isles will be constructed of asphalt concrete (AC) pavement and Portland cement concrete (PCC) pavement. Due to impervious material a shallow retention pond is proposed along the frontage of the site to retain additional runoff produced.

Access to the site is provided off West Mt. Whitney Avenue and a county standard drive approach is proposed. The proposed site will not produce excessive noise, glare, dust, or odor. The existing sewage and water supply are provided by the Riverdale Utility Water District and will remain unaffected.

The site will have existing pole lighting to illuminate the parking areas, exterior building lighting to illuminate the entry ways. Landscaping will be provided in all underdeveloped areas such that the potential for erosion and dust is limited. Existing fencing will remain around the perimeter of the site to keep the site secure.

Respectfully,

Kenny Reyes, P.E.
Project Manager

EXHIBIT 7





EXHIBIT 7 PAGE 2



