

CONTRACTOR REQUEST FOR CLARIFICATION
Project: Fresno County Sheriff Area 2 Substation
Contract No.: 19-S-04

Requests for clarification of the drawings and specifications regarding this project shall be submitted on this form. Any change or clarification shall be in the form of a written addendum issued to Bid Document holders of record. Contractors requesting clarification shall complete the following:

Email to: DesignServices@fresnocountyca.gov

FIRM NAME: HCI SYSTEMS

SENDER / CONTACT NAME: George San Mateo

MAILING ADDRESS: 3742 W. Gettysburg Ave, Suite 102 Fresno, CA 93722

BUSINESS PHONE: 559-233-2008 FAX NUMBER: 559-233-2009 Zip Code

Drawing No.:E1.3	Spec Section:283100
------------------	---------------------

Question Type or print one question below

Please advise if EST/ Edwards is an acceptable manufacturer in lieu of Gamewell-FCI in Specification Section # 28. Please reference the attached substitution request, compatibility data sheet, submittal.

Response

The following section is for County use only.

Response By:_____	Date:_____	
Included in Addendum No._____	Date:_____	
Date Received:_____	Time Received:_____ am / pm	RFC Number:_____

This form may be removed from the project specifications and/or reproduced as needed.



6/09/2020

FRESNO COUNTY DEPARTMENT PUBLIC WORKS & PLANNING

2220 TULARE ST, 8TH FLOOR

FRESNO, CA 93721

Attn: NOEL ROGER DAVIDSON

Re: Substitution

Subj: Request for Pre-Approval – Fire Alarm System

Dear Sir,

Attached you will find a request for pre-approval for the Fire Alarm system required for this project. We are requesting that EST-4 be listed as an equivalent product to the specified Gamewell-FCI system.

We have included a package of technical data sheets of the proposed product for your review.

I have reviewed the requirements of this application and I am familiar with the performance characteristics of the specified system. I am confident that our proposed system will meet the project requirements in all aspects.

I thank you for your consideration and please do not hesitate to call if you have any questions or need additional information.

Sincerely,

George San Mateo

Business Development Manager

3742 Gettysburg Ave, Ste 102

Fresno, CA 93722

Fire Alarm System Product Comparison Index

Specified Items				Proposed Items		
Item	Manufacturer	Model	Description	Manufacturer	Model	Description
1	Gamewell-FCI	E3	Fire Control Panel	EST	EST4	Fire Control Panel
2	Gamewell-FCI	NGA	Annunciator	EST	4-2ANN	Annunciator
3	Gamewell-FCI System Sensor	ASD-PL2F B501	Smoke Detector Detector Base	EST EST	SIGA-OSD SIGA-SB4	Smoke Detector Detector Base
4	Gamewell-FCI	MS-7ASF	Pull Station	EST	SIGA-278	Pull Station
5	Gamewell-FCI	AMM-4F	Monitor Module	EST	SIGA-CT1	Monitor Module
6	Gamewell-FCI	AOM-2SF	Relay Module	EST	SIGA-CR	Relay Module
7	Eaton	LSTR3	Strobes	EST	G4VWF	Strobes
8	Eaton	LHSWC3	Horn/Strobe	EST	GCAVRF	Horn/Strobe

Control Relay Modules

SIGA-CR, SIGA-MCR, SIGA-CRR, SIGA-MCRR

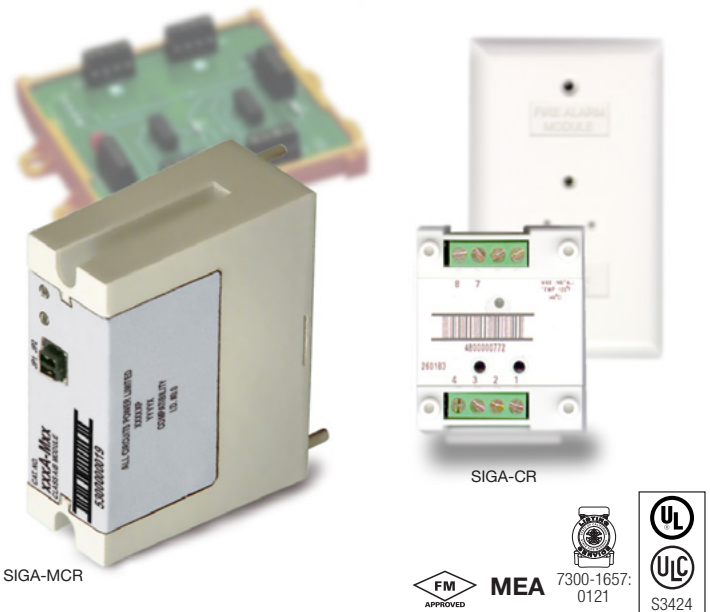

Overview

The Control Relay Module and the Polarity Reversal Relay Module are part of the Signature Series system. They are intelligent analog addressable devices available in either plug-in (UIO) versions, or standard 1-gang mount versions.

The **SIGA-CR/MCR** Control Relay Module provides a Form “C” dry relay contact to control external appliances such as door closers, fans, dampers etc. This device does not provide supervision of the state of the relay contact. Instead, the on-board microprocessor ensures that the relay is in the proper ON/OFF state. Upon command from the loop controller, the SIGA-CR/MCR relay activates the normally open or normally-closed contact.

The **SIGA-CRR/MCRR** Polarity Reversal Relay Module provides a Form “C” dry relay contact to power and activate a series of SIGA-AB4G Audible Sounder Bases. Upon command from the Signature loop controller, the SIGA-CRR reverses the polarity of its 24 Vdc output, thus activating all Sounder Bases on the data loop.

Standard-mount versions (SIGA-CR and SIGA-CRR) are installed to standard North American 1-gang electrical boxes, making them ideal for locations where only one module is required. Separate I/O and data loop connections are made to each module.

Plug-in UIO versions (SIGA-MCR and SIGA-MCRR) are part of the UIO family of plug-in Signature Series modules. They function identically to the standard mount versions, but take advantage of the modular flexibility and easy installation that characterizes all UIO modules. Two- and six-module UIO motherboards are available. All wiring connections are made to terminal blocks on the motherboard. UIO assemblies may be mounted in EDWARDS enclosures.

Standard Features

- Provides one no/nc contact (SIGA-CR/MCR)**
 Form “C” dry relay contact can be used to control external appliances such as door closers, fans, dampers etc.
- Allows group operation of sounder bases**
 The SIGA-CRR/MCRR reverses the polarity of its 24 Vdc output, thus activating all Sounder Bases on the data loop.
- Plug-in (UIO) or standard 1-gang mount**
 UIO versions allow quick installation where multiple modules are required. The 1-gang mount version is ideal for remote locations that require a single module.
- Automatic device mapping**
 Signature modules transmit information to the loop controller regarding their circuit locations with respect to other Signature devices on the wire loop.
- Electronic addressing**
 Programmable addresses are downloaded from the loop controller, a PC, or the SIGA-PRO Signature Program/Service Tool; there are no switches or dials to set.
- Intelligent device with microprocessor**
 All decisions are made at the module to allow lower communication speed with substantially improved control panel response time and less sensitivity to line noise and loop wiring properties; twisted or shielded wire is not required.

Installation

SIGA-CR and SIGA-CRR: modules mount to North American 2½ inch (64 mm) deep 1-gang boxes and 1½ inch (38 mm) deep 4 inch square boxes with 1-gang covers and SIGA-MP mounting plates. The terminals are suited for #12 to #18 AWG (2.5 mm² to 0.75 mm²) wire size.

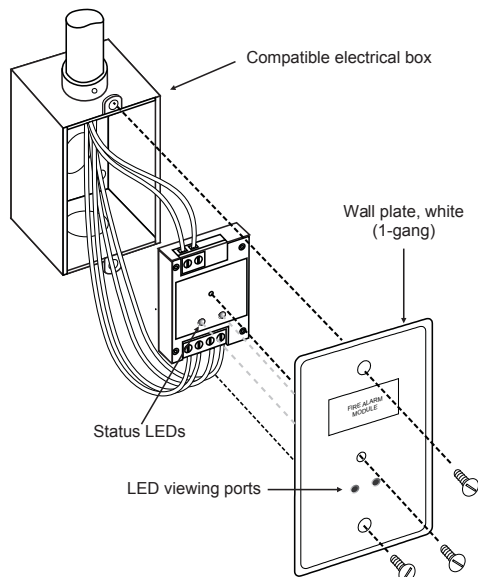

SIGA-MCR and SIGA-MCRR: mount the UIO motherboard inside a suitable EDWARDS enclosure with screws and washers provided. Plug the module into any available position on the motherboard and secure the module to the motherboard with the captive screws. Wiring connections are made to the terminals on the motherboard (see wiring diagram). UIO motherboard terminals are suited for #12 to #18 AWG (2.5 mm² to 0.75 mm²) wire size.

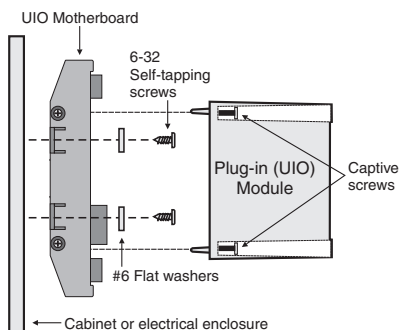

Electronic Addressing - The loop controller electronically addresses each module, saving valuable time during system commissioning. Setting complicated switches or dials is not required. Each module has its own unique serial number stored in its on-board memory. The loop controller identifies each device on the loop and assigns a “soft” address to each serial number. If desired, the modules can be addressed using the SIGA-PRO Signature Program/Service Tool.

EDWARDS recommends that this module be installed according to latest recognized edition of national and local fire alarm codes.

Application

The operation of Signature Series control relays is determined by their sub-type code or “Personality Code.”

Personality Code 8: CONTROL RELAY (SIGA-CR/MCR) - Dry Contact Output. This setting configures the module to provide one Form “C” DRY RELAY CONTACT to control Door Closers, Fans, Dampers, etc. Contact rating is 2.0 amp @ 24 Vdc; 0.5 amp @ 120 Vac (or 0.25A @ 220 Vac for non-UL applications). Personality Code 8 is assigned at the factory. No user configuration is required.

Personality Code 8: POLARITY REVERSAL RELAY MODULE (SIGA-CRR/MCRR). This setting configures the module to reverse the polarity of its 24 Vdc output. Contact rating is 2.0 amp @ 24 Vdc (pilot duty). Personality Code 8 is assigned at the factory. No user configuration is required.

Compatibility

These modules are part of EDWARDS’s Signature Series intelligent processing and control platform. They are compatible with EST3, EST3X and iO Series control panels.

Warnings & Cautions

This module will not operate without electrical power. As fires frequently cause power interruption, we suggest you discuss further safeguards with your local fire protection specialist.

Testing & Maintenance

The module’s automatic self-diagnosis identifies when it is defective and causes a trouble message. The user-friendly maintenance program shows the current state of each module and other pertinent messages. Single modules may be turned off (deactivated) temporarily, from the control panel. Availability of maintenance features is dependent on the fire alarm system used. Scheduled maintenance (Regular or Selected) for proper system operation should be planned to meet the requirements of the Authority Having Jurisdiction (AHJ). Refer to current NFPA 72 and ULC CAN/ULC 536 standards.

Typical Wiring

Modules will accept #18 AWG (0.75mm²), #16 (1.0mm²), #14 AWG (1.50mm²) and #12 AWG (2.5mm²) wire sizes.

Note: Sizes #16 AWG (1.0mm²) and #18 AWG (0.75mm²) are preferred for ease of installation. See Signature Loop Controller catalog sheet for detailed wiring requirement specifications.

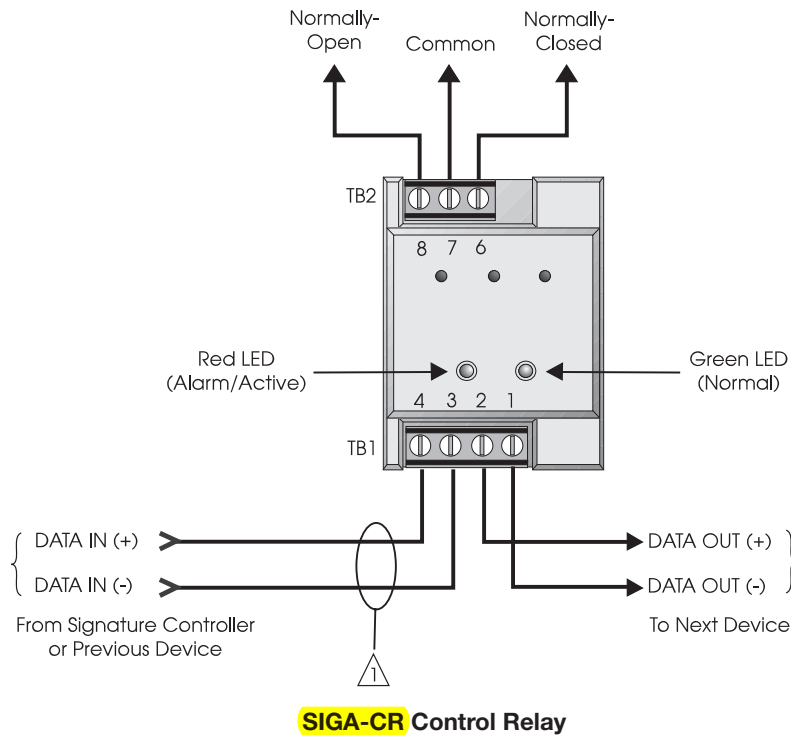

Notes

- 1 Refer to Signature Loop Controller Installation Sheet for wiring specifications.
- 2 NFPA 72 requires that the **SIGA-CR/SIGA-MCR** be installed in the same room as the device it is controlling. This requirement may not apply in all markets. Check with your local AHJ for details.
- 3 The SIGA-UIO6R and the SIGA-UIO2R do not come with TB14.
- 4 The SIGA-UIO6 does not come with TB8 through TB13.
- 5 Supervised and power-limited.
- 6 If the source is nonpower-limited, maintain a space of 1/4 inch from power-limited wiring or use FPL, FPLP, FPLR, or an equivalent in accordance with the National Electrical Code.
- 7) Maximum #12 AWG (2.5mm²) wire. Min. #18 (0.75mm²).

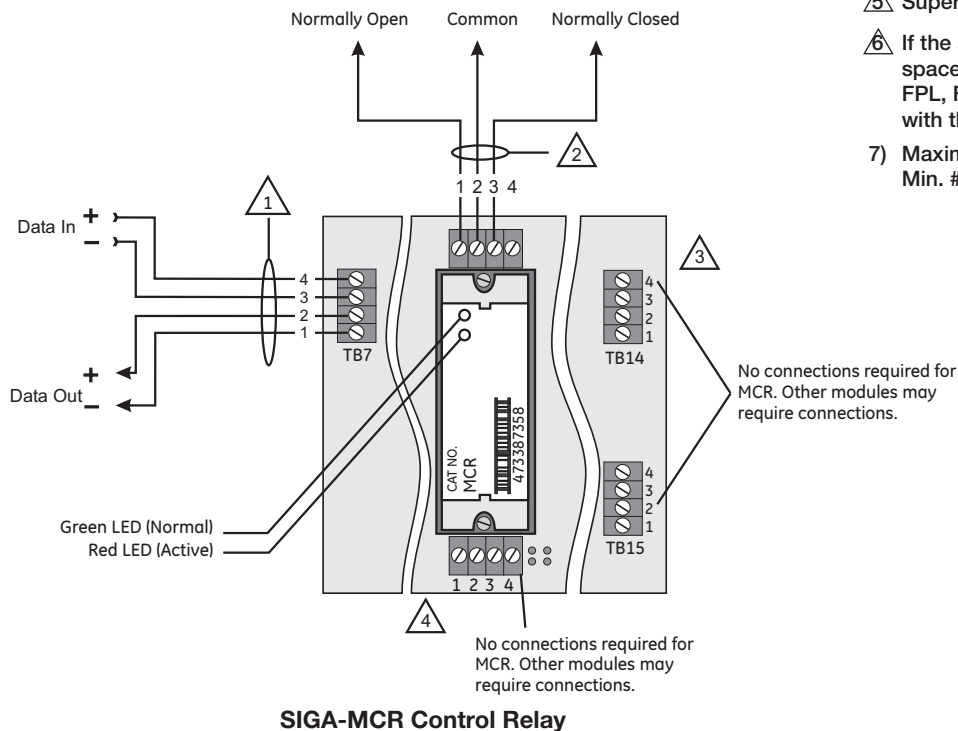

Typical Wiring

Modules will accept #18 AWG (0.75mm²), #16 (1.0mm²), #14 AWG (1.50mm²) and #12 AWG (2.50mm²) wire sizes.

Note: Sizes #16 AWG (1.0mm²) and #18 AWG (0.75mm²) are preferred for ease of installation. See Signature Loop Controller catalog sheet for detailed wiring requirement specifications.

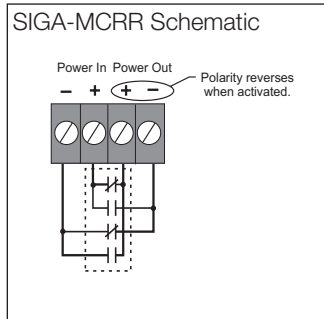
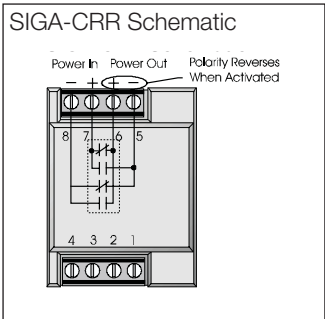
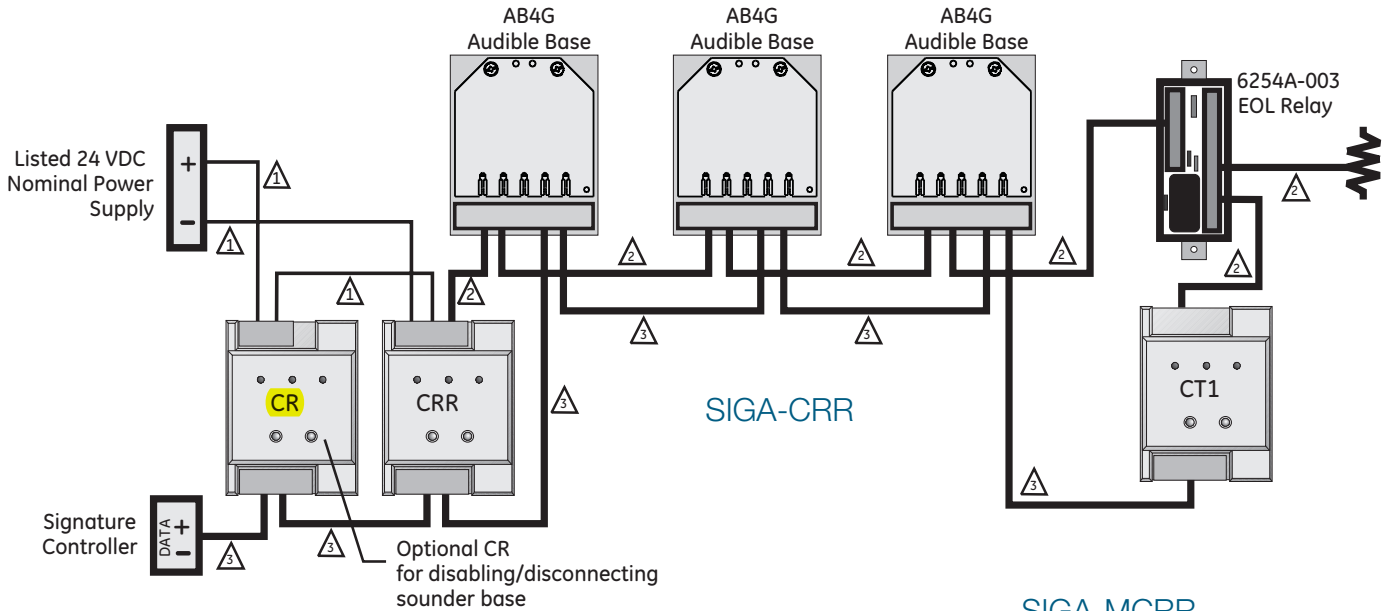

SIGA-MCRR

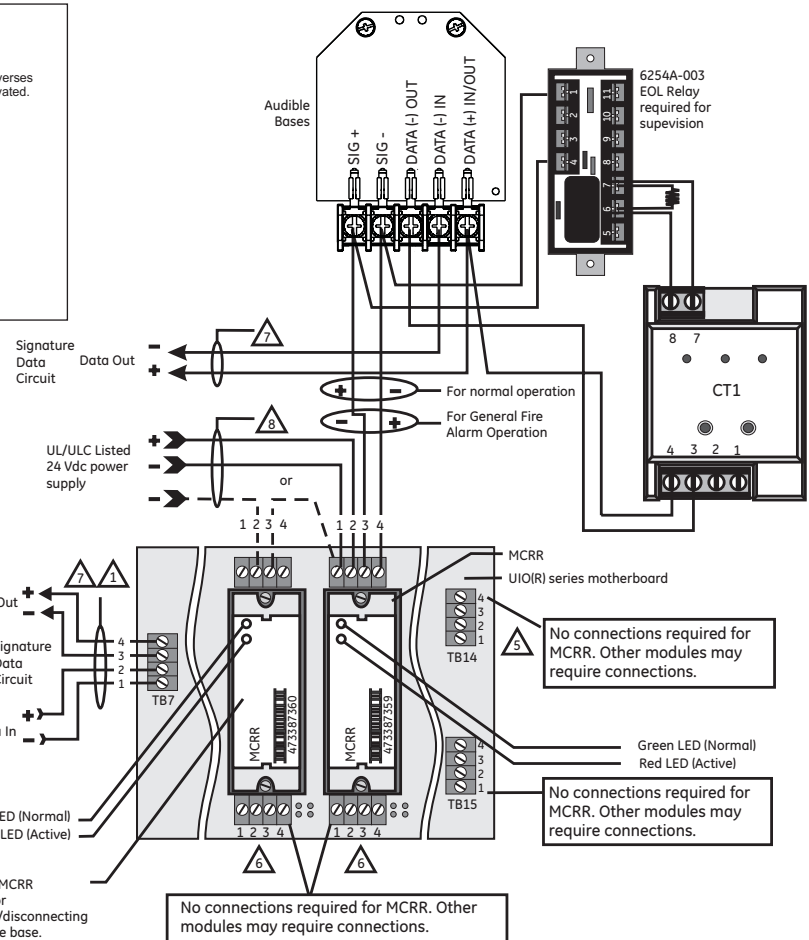

Notes

- ⚠ Refer to the Signature controller installation sheet for wiring.
- ⚡ One Pair of Wires (24 Vdc power).
- ⚡ One Pair of Wires (Signature Data).
- ⚡ Single Wire (24 Vdc power).
- ⚠ The SIGA-UIO6R and the SIGA-UIO2R do not come with TB14.
- ⚠ The SIGA-UIO6 does not come with TB8 through TB13.
- ⚠ Supervised and power-limited.
- ⚠ If the source is nonpower-limited, maintain a space of 1/4 inch from power-limited wiring or use FPL, FPLP, FPLR, or an equivalent in accordance with the National Electrical Code.
- 9 Maximum #12 AWG (2.5 mm²) wire; Minimum #18 AWG (0.75 mm²).
- 10 End-of-Line Relay must monitor and report power supply trouble to control panel.
- 11 Class B Data wiring may be "T-tapped."

Specifications

Catalog Number	SIGA-CR	SIGA-MCR	SIGA-CRR	SIGA-MCRR
Description	Control Relay		Polarity Reversal Relay	
Type Code	Personality Code 8 (Factory Set)		Personality Code 8 (Factory Set)	
Address Requirements	Uses 1 Module Address			
Operating Current	Standby = 75 μ A Activated = 75 μ A			
Operating Voltage	15.2 to 19.95 Vdc (19 Vdc nominal)			
Relay Type and Rating	Form C, 2 Amps @ 24 Vdc (pilot duty), 0.5 Amps @ 120 Vac and 0.25 Amps @ 220 Vac (220 Vac is non-UL) Not rated for capacitive loads.			
Mounting	North American 2½ inch (64 mm) deep 1-gang boxes and 1½ inch (38 mm) deep 4 inch square boxes with 1-gang covers and SIGA-MP mounting plates	Plugs into UIO2R, UIO6R or UIO6 Motherboards	North American 2½ inch (64 mm) deep 1-gang boxes and 1½ inch (38 mm) deep 4 inch square boxes with 1-gang covers and SIGA-MP mounting plates	Plugs into UIO2R, UIO6R or UIO6 Motherboards
Construction & Finish	High Impact Engineering Polymer			
Storage and Operating Environment	Operating Temperature: 32°F to 120°F (0°C to 49°C) Storage Temperature: -4°F to 140°F (-20°C to 60°C) Humidity: 0 to 93% RH			
LED Operation	On-board Green LED - Flashes when polled On-board Red LED - Flashes when in alarm/active			
Compatibility	Use With: Signature Loop Controller			
Agency Listings	UL, ULC, CSFM, MEA			

Ordering Information

Catalog Number	Description	Ship Weight - lbs (kg)
SIGA-CR	Control Relay Module (Standard Mount)	0.4 (0.15)
SIGA-MCR	Control Relay Module (UIO Mount)	0.18 (0.08)
SIGA-CRR	Polarity Reversal Relay Module (Standard Mount)	0.4 (0.15)
SIGA-MCRR	Polarity Reversal Relay Module (UIO Mount)	0.18 (0.08)

Related Equipment		
27193-11	Surface Mount Box - Red, 1-gang	1 (0.6)
27193-16	Surface Mount Box - White, 1-gang	1 (0.6)
SIGA-UIO2R	Universal Input-Output Module Board w/Riser Inputs - Two Module Positions	0.32 (0.15)
SIGA-UIO6R	Universal Input-Output Module Board w/Riser Inputs - Six Module Positions	0.62 (0.28)
SIGA-UIO6	Universal Input-Output Module Board - Six Module Positions	0.56 (0.25)
SIGA-AB4G	Audible (Sounder) Detector Base	0.3 (0.15)

Accessories		
MFC-A	Multifunction Fire Cabinet - Red, supports Signature Module Mounting Plates	7.0 (3.1)
SIGA-MB4	Transponder Mounting Bracket (allows for mounting two 1-gang modules in a 2-gang box)	0.4 (0.15)
SIGA-MP1	Signature Module Mounting Plate, 1 footprint	1.5 (0.70)
SIGA-MP2	Signature Module Mounting Plate, 1/2 footprint	0.5 (0.23)
SIGA-MP2L	Signature Module Mounting Plate, 1/2 extended footprint	1.02 (0.46)



LIFE SAFETY & INCIDENT MANAGEMENT

Contact us...

Email: edwards.fire@fs.utc.com
Web: Edwards-fire.com

EDWARDS is a UTC brand.
1016 Corporate Park Drive
Mebane, NC 27302

© 2016 United Technologies Corporation.
All rights reserved.

Signature Series Overview

The Signature Series intelligent analog-addressable system from EDWARDS is an entire family of multi-sensor detectors and mounting bases, multiple-function input and output modules, network and non-network control panels, and user-friendly maintenance and service tools. Analog information from equipment connected to Signature devices is gathered and converted into digital signals. An onboard microprocessor in each Signature device measures and analyzes the signal and decides whether or not to input an alarm. The microprocessor in each Signature device provides four additional benefits – Self-diagnostics and History Log, Automatic Device Mapping, and Fast, Stable Communication.

Self-diagnostics and History Log – Each Signature Series device constantly runs self-checks to provide important maintenance information. The results of the self-check are automatically updated and permanently stored in its non-volatile memory. This information is accessible for review any time at the control panel, PC, or using the SIGA-PRO Signature Program/Service Tool. The information stored in device memory includes:

- Device serial number, address, and type
- Time and date of last alarm
- Most recent trouble code logged by the detector — 32 possible trouble codes may be used to diagnose faults.

Automatic Device Mapping –The Signature Data Controller (SDC) learns where each device's serial number address is installed relative to other devices on the circuit. The SDC keeps a map of all Signature Series devices connected to it. The Signature Series Data Entry Program also uses the mapping feature. With interactive menus and graphic support, the wired circuits between each device can be examined. Layout or “as-built” drawing information showing branch wiring (T-taps), device types and their address are stored on disk for printing hard copy. This takes the mystery out of the installation. The preparation of as-built drawings is fast and efficient.

Device mapping allows the Signature Data Controller to discover:

- Unexpected additional device addresses
- Missing device addresses
- Changes to the wiring in the circuit.

Most Signature modules use a personality code selected by the installer to determine their actual function. Personality codes are downloaded from the SDC during system configuration and are indicated during device mapping.



LIFE SAFETY & INCIDENT MANAGEMENT

Input Modules

SIGA-CT1, SIGA-CT1HT,
SIGA-CT2, SIGA-MCT2

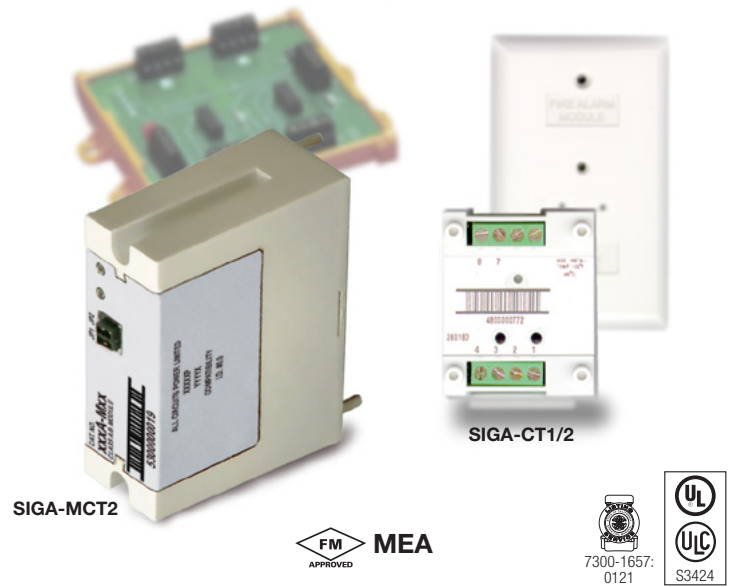

Overview

The **SIGA-CT1** Single Input Module, SIGA-CT1HT High Temperature Single Input Module and SIGA-CT2/SIGA-MCT2 Dual Input Modules are intelligent analog addressable devices used to connect one or two Class B normally-open Alarm, Supervisory, or Monitor type dry contact Initiating Device Circuits (IDC).

The actual function of these modules is determined by the “personality code” selected by the installer. This code is downloaded to the module from the Signature loop controller during system configuration.

The input modules gather analog information from the initiating devices connected to them and convert it into digital signals. The module’s on-board microprocessor analyzes the signal and decides whether or not to input an alarm.

The **SIGA-CT1**, **SIGA-CT1HT** and **SIGA-CT2** mount to standard North American 1-gang electrical boxes, making them ideal for locations where only one module is required. Separate I/O and data loop connections are made to each module.

The SIGA-CT1HT module operates at an expanded temperature range of 32 °F to 158 °F (0 °C to 70 °C) for those applications requiring more extreme environmental temperature variation.

The **SIGA-MCT2** is part of the UIO family of plug-in Signature Series modules. It functions identically to the SIGA-CT2, but takes advantage of the modular flexibility and easy installation that characterizes all UIO modules. Two- and six-module UIO motherboards are available. All wiring connections are made to terminal blocks on the motherboard. UIO assemblies may be mounted in EDWARDS enclosures.

Standard Features

- **Multiple applications**
Including Alarm, Alarm with delayed latching (retard) for water-flow applications, Supervisory, and Monitor. The installer selects one of four “personality codes” to be downloaded to the module through the loop controller.
- **SIGA-CT1HT rated for high temperature environments**
Suitable for attic installation and monitoring high temperature heat detectors.
- **Plug-in (UIO) or standard 1-gang mount**
UIO versions allow quick installation where multiple modules are required. The 1-gang mount version is ideal for remote locations that require a single module.
- **Automatic device mapping**
Signature modules transmit information to the loop controller regarding their circuit locations with respect to other Signature devices on the wire loop.
- **Electronic addressing**
Programmable addresses are downloaded from the loop controller, a PC, or the SIGA-PRO Signature Program/Service Tool. There are no switches or dials to set.
- **Ground fault detection by address**
Detects ground faults right down to the device level.

Signature Series Overview

The Signature Series intelligent analog-addressable system from EDWARDS Security is an entire family of multi-sensor detectors and mounting bases, multiple-function input and output modules, network and non-network control panels, and user-friendly maintenance and service tools. Analog information from equipment connected to Signature devices is gathered and converted into digital signals. An onboard microprocessor in each Signature device measures and analyzes the signal and decides whether or not to input an alarm. The microprocessor in each Signature device provides four additional benefits – Self-diagnostics and History Log, Automatic Device Mapping, and Fast, Stable Communication.

Self-diagnostics and History Log – Each Signature Series device constantly runs self-checks to provide important maintenance information. The results of the self-check are automatically updated and permanently stored in its non-volatile memory. This information is accessible for review any time at the control panel, PC, or using the SIGA-PRO Signature Program/Service Tool.

Automatic Device Mapping – The Signature Data Controller (SDC) learns where each device's serial number address is installed relative to other devices on the circuit. The SDC keeps a map of all Signature Series devices connected to it. The Signature Series Data Entry Program also uses the mapping feature. With interactive menus and graphic support, the wired circuits between each device can be examined. Layout or “as-built” drawing information showing branch wiring (T-taps), device types and their address are stored on disk for printing hard copy.

Installation

SIGA-CT1, SIGA-CT1HT and SIGA-CT2: modules mount to North American 2½ inch (64 mm) deep 1-gang boxes and 1½ inch (38 mm) deep 4 inch square boxes with 1-gang covers and SIGA-MP mounting plates. The terminals are suited for #12 to #18 AWG (2.5 mm² to 0.75 mm²) wire size.

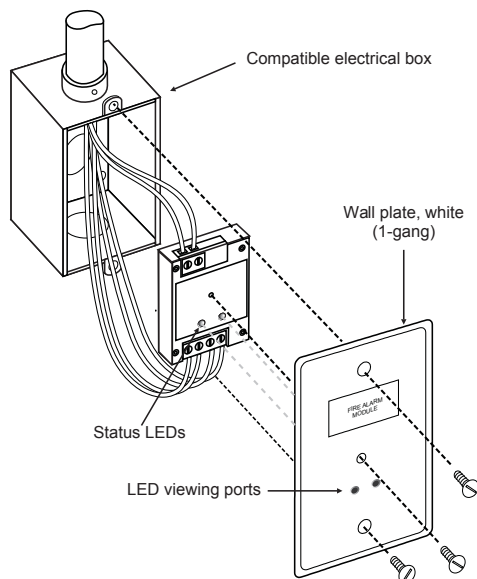

SIGA-MCT2: mount the UIO motherboard inside a suitable EDWARDS enclosure with screws and washers provided. Plug the SIGA-MCT2 into any available position on the motherboard and secure the module to the motherboard with the captive screws. Wiring connections are made to the terminals on the motherboard (see wiring diagram). UIO motherboard terminals are suited for #12 to #18 AWG (2.5 mm² to 0.75 mm²) wire size.

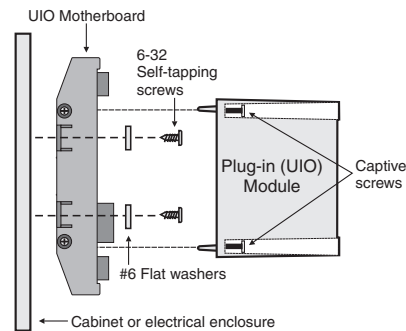

Electronic Addressing - The loop controller electronically addresses each module, saving valuable time during system commissioning. Setting complicated switches or dials is not required. Each module has its own unique serial number stored in its on-board memory. The loop controller identifies each device on the loop and assigns a “soft” address to each serial number. If desired, the modules can be addressed using the SIGA-PRO Signature Program/Service Tool.

EDWARDS recommends that this module be installed according to latest recognized edition of national and local fire alarm codes.

Application

The duty performed by the **SIGA-CT1** and SIGA-CT2/MCT2 is determined by their sub-type code or “Personality Code”. The code is selected by the installer depending upon the desired application and is downloaded from the loop controller.

One personality code can be assigned to the **SIGA-CT1**. Two personality codes can be assigned to the SIGA-CT2/MCT2. Codes 1, 2, 3 and 4 can be mixed on SIGA-CT2/MCT2 modules only. For example, personality code 1 can be assigned to the first address (circuit A) and code 4 can be assigned to the second address (circuit B).

NORMALLY-OPEN ALARM - LATCHING (Personality Code 1)

- Assign to one or both circuits. Configures either circuit A or B or both for Class B normally open dry contact initiating devices such as Pull Stations, Heat Detectors, etc. An ALARM signal is sent to the loop controller when the input contact is closed. The alarm condition is latched at the module.

NORMALLY-OPEN ALARM - DELAYED LATCHING (Personality Code 2)

- Assign to one or both circuits. Configures either circuit A or B or both for Class B normally-open dry contact initiating devices such as Waterflow Alarm Switches. An ALARM signal is sent to the loop controller when the input contact is closed for approximately 16 seconds. The alarm condition is latched at the module.

NORMALLY-OPEN ACTIVE - NON-LATCHING (Personality Code 3)

- Assign to one or both circuits. Configures either circuit A or B or both for Class B normally-open dry contact monitoring input such as from Fans, Dampers, Doors, etc. An ACTIVE signal is sent to the loop controller when the input contact is closed. The active condition is not latched at the module.

NORMALLY-OPEN ACTIVE - LATCHING (Personality Code 4)

- Assign to one or both circuits. Configures either circuit A or B or both for Class B normally open dry contact monitoring input such as from Supervisory and Tamper Switches. An ACTIVE signal is sent to the loop controller when the input contact is closed. The active condition is latched at the module.

Typical Wiring

Modules will accept #18 AWG (0.75mm²), #16 (1.0mm²), and #14AWG (1.50mm²), and #12 AWG (2.50mm²) wire sizes.

Note: Sizes #16 AWG (1.0mm²) and #18 AWG (0.75mm²) are preferred for ease of installation. See Signature Loop Controller catalog sheet for detailed wiring requirement specifications.

Initiating (Slave) Device Circuit Wire Specifications

Maximum Allowable Wire Resistance	50 ohms (25 ohms per wire) per Circuit	
Maximum Allowable Wire Capacitance	0.1µF per Circuit	
For Design Reference:	Wire Size	Maximum Distance to EOLR
	#18 AWG (0.75 mm ²)	4,000 ft (1,219 m)
	#16 AWG (1.00 mm ²)	
	#14 AWG (1.50 mm ²)	
	#12 AWG (1.50 mm ²)	

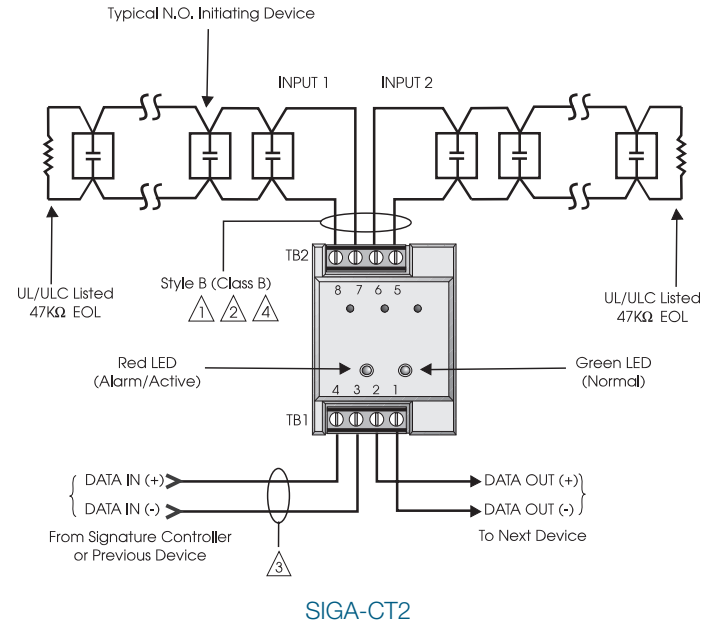
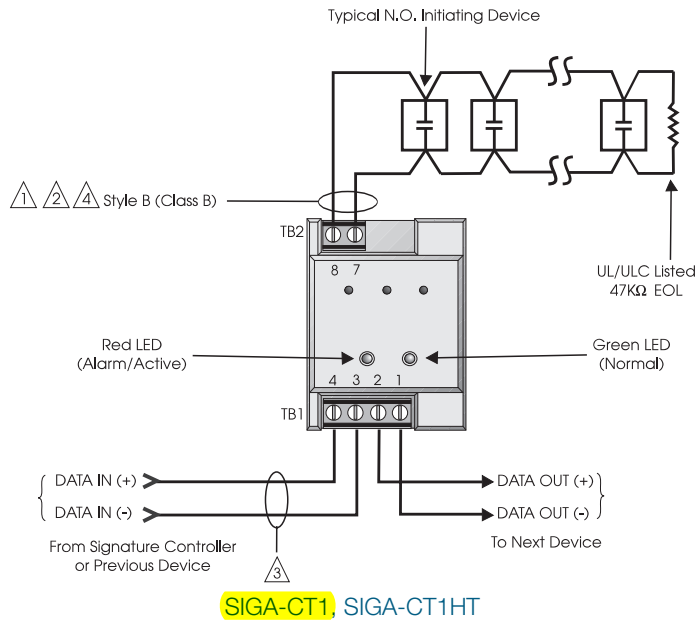

NOTES

- ① Maximum 25 Ohm resistance per wire.
- ② Maximum #12 AWG (2.5 mm²) wire; Minimum #18 AWG (0.75 mm²).
- ③ Refer to Signature controller installation sheet for wiring specifications.
- ④ Maximum 10 Vdc @ 350 µA
- ⑤ The SIGA-UIO6R and the SIGA-UIO2R do not come with TB14.
- 6 All wiring is supervised and power-limited.
- 7 These modules will not support 2-wire smoke detectors.

Warnings & Cautions

This module will not operate without electrical power. As fires frequently cause power interruption, we suggest you discuss further safeguards with your local fire protection specialist.

Compatibility

These modules are part of EDWARDS's Signature Series intelligent processing and control platform. They are compatible with EST3, EST3X and iO Series control panels.

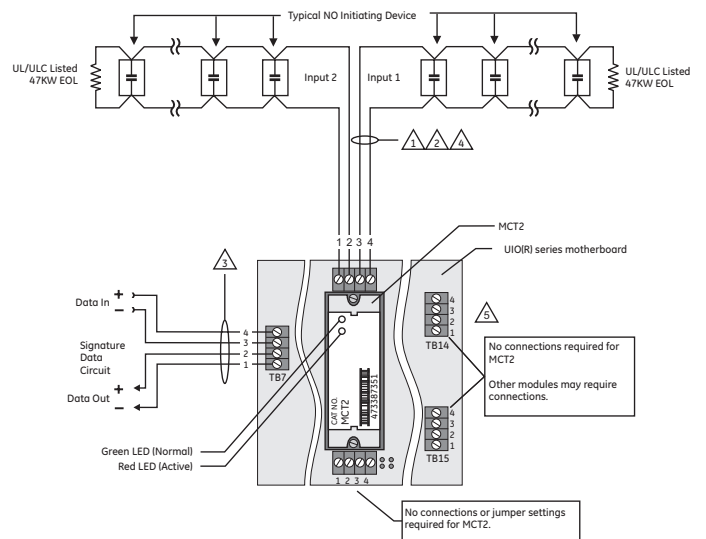



LIFE SAFETY & INCIDENT MANAGEMENT

Contact us...

Email: edwards.fire@fs.utc.com
 Web: Edwards-fire.com

EDWARDS is a UTC brand.
 1016 Corporate Park Drive
 Mebane, NC 27302

© 2016 United Technologies Corporation.
 All rights reserved.

Specifications

Catalog Number	SIGA-CT1HT	SIGA-CT1	SIGA-CT2	SIGA-MCT2
Description	Single Input Module		Dual Input Module	
Type Code	48 (factory set) Four sub-types (personality codes) are available		49 (factory set) Four sub-types (personality codes) are available	
Address Requirements	Uses One Module Address		Uses Two Module Addresses	
Operating Current	Standby = 250µA; Activated = 400µA		Standby = 396µA; Activated = 680µA	
Operating Voltage	15.2 to 19.95 Vdc (19 Vdc nominal)			
Construction	High Impact Engineering Polymer			
Mounting	North American 2½ inch (64 mm) deep one-gang boxes and 1½ inch (38 mm) deep 4 inch square boxes with one-gang covers and SIGA-MP mounting plates			UIO2R/6R/6 Motherboard
Operating Environment	32°F to 158°F (0°C to 70°C)	32°F to 120°F (0°C to 49°C)		
Storage Environment	-4°F to 140°F (-20°C to 60°C); Humidity: 0 to 93% RH			
LED Operation	On-board Green LED - Flashes when polled; On-board Red LED - Flashes when in alarm/active.			
Compatibility	Use with Signature Loop Controller			
Agency Listings	UL, ULC, MEA, CSFM			

Ordering Information

Catalog Number	Description	Ship Wt. lbs (kg)
SIGA-CT1	Single Input Module — UL/ULC Listed	0.4 (0.15)
SIGA-CT1HT	Single Input Module High Temperature Operation UL/ULC Listed	0.4 (0.15)
SIGA-CT2	Dual Input Module — UL/ULC Listed	0.4 (0.15)
SIGA-MCT2	Dual Input Plug-in (UIO) Module — UL, ULC Listed	0.1 (0.05)

Related Equipment		
27193-11	Surface Mount Box - Red, 1-gang	1.0 (0.6)
27193-16	Surface Mount Box - White, 1-gang	1.0 (0.6)
SIGA-UIO2R	Universal Input-Output Module Board w/Riser Inputs — Two Module Positions	0.32 (0.15)
SIGA-UIO6R	Universal Input-Output Module Board w/Riser Inputs — Six Module Positions	0.62 (0.28)
SIGA-UIO6	Universal Input-Output Module Board — Six Module Positions	0.56 (0.25)
MFC-A	Multifunction Fire Cabinet — Red, supports Signature Module Mounting Plates	7.0 (3.1)
SIGA-MB4	Transponder Mounting Bracket (allows for mounting two 1-gang modules in a 2-gang box)	0.4 (0.15)
SIGA-MP1	Signature Module Mounting Plate, 1 footprint	1.5 (0.70)
SIGA-MP2	Signature Module Mounting Plate, 1/2 footprint	0.5 (0.23)
SIGA-MP2L	Signature Module Mounting Plate, 1/2 extended footprint	1.02 (0.46)



LIFE SAFETY & INCIDENT MANAGEMENT

Manual Pull Stations

SIGA-270, SIGA-270P,
SIGA-278



SIGA-278

SIGA-270 SERIES

Patented

MEA FM 7150-1657:
 APPROVED 0129



Overview

The SIGA-270 and **SIGA-278** series Manual Pull Stations are part of EDWARDS's Signature Series system. The SIGA-270 Fire Alarm Manual Pull Stations feature our very familiar teardrop shape. They are made from die-cast zinc and finished with red epoxy powder-coat paint complemented by aluminum colored stripes and markings. With positive pull-lever operation, one pull on the station handle breaks the glass rod and turns in a positive alarm, ensuring protection plus fool-proof operation. Presignal models (SIGA-270P) are equipped with a general alarm (GA) keyswitch for applications where two stage operation is required. The up-front highly visible glass rod discourages tampering, but is not required for proper operation.

EDWARDS's double action single stage **SIGA-278** station is a contemporary style manual station made from durable red colored lexan. To initiate an alarm, first lift the upper door marked "LIFT THEN PULL HANDLE", then pull the alarm handle.

Standard Features

Note: Some features described here may not be supported by all control systems. Check your control panel's Installation and Operation Guide for details.

- **Traditional familiar appearance**
 SIGA-270 models feature our familiar teardrop design with simple positive pull action and sturdy die-cast metal body.
- **One stage (GA), two stage (pre-signal), and double action models**
 SIGA-270 models are available for one or two stage alarm systems. The single stage double action SIGA-278 features a rugged Lexan housing with keyed reset mechanism.

- **Break glass operation**
 An up-front visible glass rod on the SIGA-270 discourages tampering.
- **Intelligent device with integral microprocessor**
 All decisions are made at the station allowing lower communication speed while substantially improving control panel response time. Less sensitive to line noise and loop wiring properties; twisted or shielded wire is not required.
- **ADA Compliant**
 Meets ADA requirements for manual pull stations.
- **Electronic Addressing with Non-volatile memory**
 Permanently stores programmable address, serial number, type of device, and job number. Automatically updates historic information including hours of operation, last maintenance date, number of alarms and troubles, and time and date of last alarm.
- **Automatic device mapping**
 Each station transmits wiring information to the loop controller regarding its location with respect to other devices on the circuit.
- **Diagnostic LEDs**
 Status LEDs; flashing GREEN shows normal polling; flashing RED shows alarm state.
- **Designed for high ambient temperature operation**
 Install in ambient temperatures up to 120 °F (49 °C).

Application

The operating characteristics of the fire alarm stations are determined by their sub-type code or "Personality Code". NORMALLY-OPEN ALARM - LATCHING (Personality Code 1) is assigned by the factory; no user configuration is required. The device is configured for Class B IDC operation. An ALARM signal is sent to the loop controller when the station's pull lever is operated. The alarm condition is latched at the station.

Compatibility

Signature Series manual stations are compatible only with EDWARDS's Signature Loop Controller.

Warnings & Cautions

This device will not operate without electrical power. As fires frequently cause power interruption, we suggest you discuss further safeguards with your local fire protection specialist.

Testing & Maintenance

To test (or reset) the station simply open the station and operate the exposed switch. The SIGA-270 series are opened with a tool; the SIGA-278 requires the key which is supplied with that station.

The station's automatic self-diagnosis identifies when it is defective and causes a trouble message. The user-friendly maintenance program shows the current state of each Signature series device and other pertinent messages. Single devices may be deactivated temporarily, from the control panel. Availability of maintenance features is dependent on the fire alarm system used.

Scheduled maintenance (Regular or Selected) for proper system operation should be planned to meet the requirements of the Authority Having Jurisdiction (AHJ). Refer to current NFPA 72 and ULC CAN/ULC 536 standards.

Typical Wiring

The fire alarm station's terminal block accepts #18 AWG (0.75mm²) to #12 AWG (2.5mm²) wire sizes. See Signature Loop Controller catalog sheet for detailed wiring requirement specifications.

Wiring Notes

1. Refer to Signature Loop Controller manual for maximum wire distance.
2. All wiring is power limited and supervised.

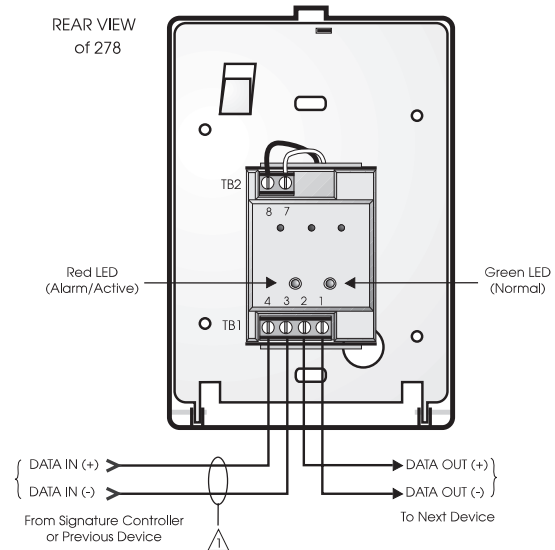

Figure 4. Single Stage Systems

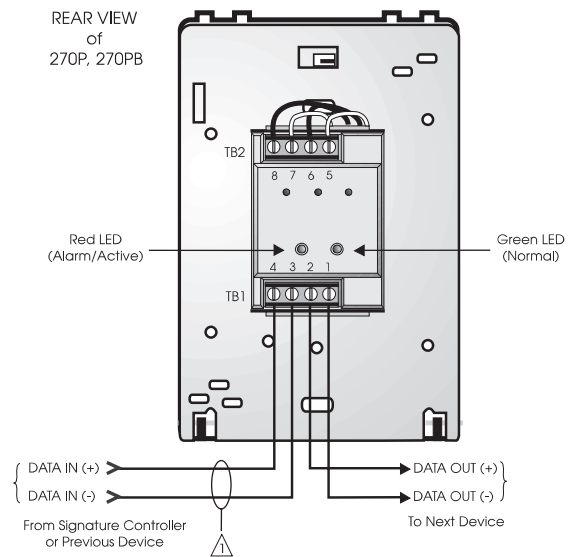

Figure 5. Two Stage Systems

Installation

Single-stage Signature Series fire alarm manual pull stations mount to North American 2½ inch (64 mm) deep 1-gang boxes.

Two stage presignal (270P) models require 1½ inch (38 mm) deep 4-inch square boxes with 1-gang, ½-inch raised covers. Openings must be angular. *Rounded openings are not acceptable.* Recommended box: Steel City Model 52-C-13; in Canada, use Iberville Model CI-52-C-49-1/2.

All models include terminals are suited for #12 to #18 AWG (2.5 mm² to 0.75 mm²) wire size. EDWARDS recommends that these fire alarm stations be installed according to latest recognized edition of national and local fire alarm codes.

Electronic Addressing: The loop controller electronically addresses each manual station, saving valuable time during system commissioning. Setting complicated switches or dials is not required. Each station has its own unique serial number stored in its on-board memory. The loop controller identifies each device on the loop and assigns a “soft” address to each serial number. If desired, the stations can be addressed using the SIGA-PRO Signature Program/Service Tool.

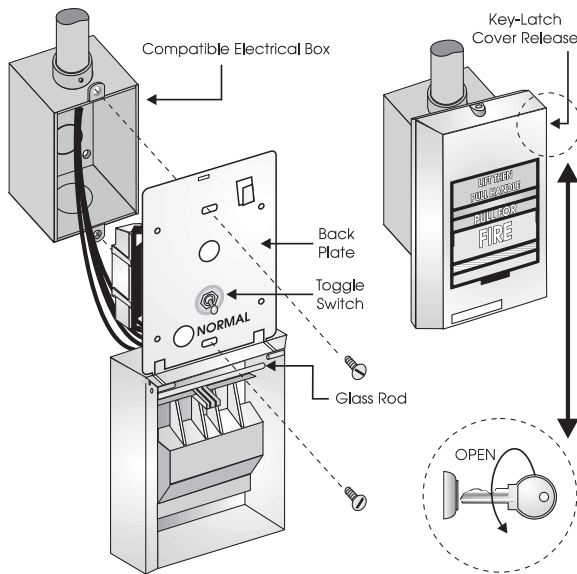

Figure 1. SIGA-278 installation

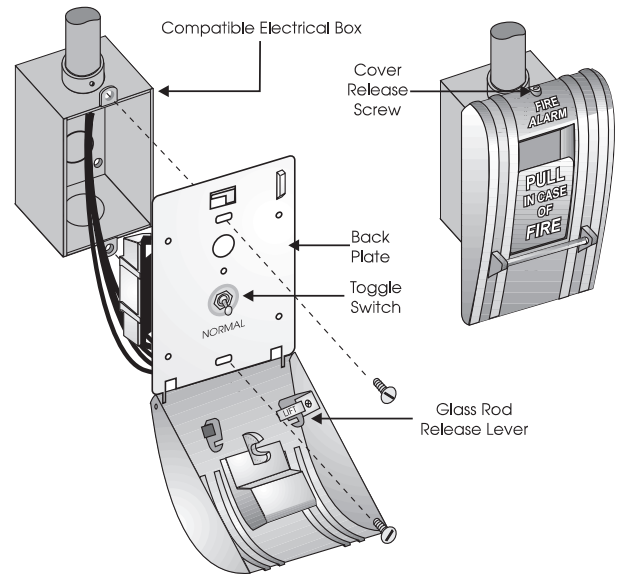

Figure 2. SIGA-270, SIGC-270F, SIGC-270B installation

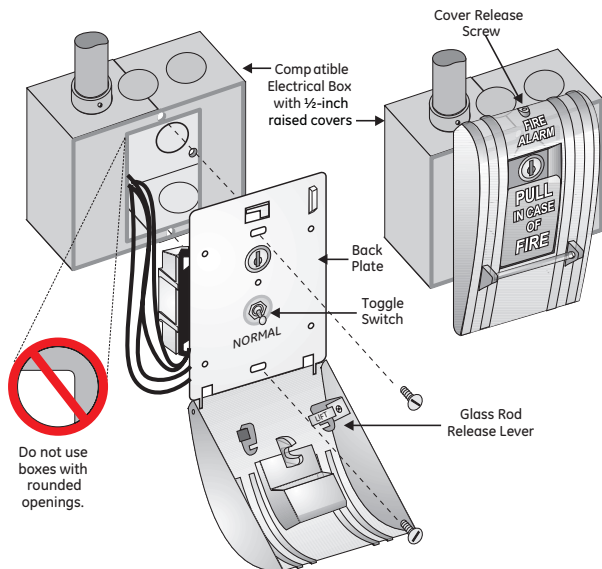

Figure 3. SIGA-270P, SIGC-270PB installation



LIFE SAFETY & INCIDENT MANAGEMENT

Contact us...

Email: edwards.fire@fs.utc.com
 Web: Edwards-fire.com

EDWARDS is a UTC brand.
 1016 Corporate Park Drive
 Mebane, NC 27302

© 2016 United Technologies Corporation.
 All rights reserved.

Specifications

Catalog Number	SIGA-270, SIGC-270F, SIGC-270B	SIGA-270P, SIGC-270PB	SIGA-278
Description	Single Action - One Stage	Single Action -Two Stage (Presignal)	Double Action - One Stage
Addressing Requirements	Uses 1 Module Address	Uses 2 Module Addresses	Uses 1 Module Address
Operating Current	Standby = 250µA Activated = 400µA	Standby = 396µA Activated = 680µA	Standby = 250µA Activated = 400µA
Construction & Finish	Diecast Zinc - Red Epoxy with aluminum markings		Lexan - Red with white markings
Type Code	Factory Set		
Operating Voltage	15.2 to 19.95 Vdc (19 Vdc nominal)		
Storage and Operating Environment	Operating Temperature: 32°F to 120°F (0°C to 49°C) Storage Temperature: -4°F to 140°F (-20°C to 60°C) Humidity: 0 to 93% RH		
LED Operation	On-board Green LED - Flashes when polled On-board Red LED - Flashes when in alarm		
Compatibility	Use With: Signature Loop Controller		
Agency Listings	UL, ULC (note 1), MEA, CSFM, FM		

Note: SIGC-270F, SIGC-270B and SIGC-270PB are ULC listed only. Suffix "F" indicates French markings. Suffix "B" indicates English/French bilingual markings.

Ordering Information

Catalog Number	Description	Ship Wt. lbs (kg)
SIGA-270	One Stage Fire Alarm Station, English Markings - UL/ULC Listed	
SIGC-270F	One Stage Fire Alarm Station, French Markings - ULC Listed	
SIGC-270B	One Stage Fire Alarm Station, French/English Markings - ULC Listed	
SIGA-270P	Two Stage (Presignal) Fire Alarm Station, English Markings - UL/ULC Listed	1 (0.5)
SIGC-270PB	Two Stage (Presignal) Fire Alarm Station, French/English Markings - ULC Listed	
SIGA-278	Double Action (One Stage) Fire Alarm Station, English Markings - UL/ULC Listed	

Accessories

32997	GA Key w/Tag - for pre-signal station (CANADA ONLY)	
276-K2	GA Key - for pre-signal station (USA ONLY)	
276-K1	Station Reset Key, Supplied with all Key Reset Stations	0.1 (.05)
27165	12 Glass Rods - for SIGA-270 series (CANADA ONLY)	
270-GLR	20 Glass Rods - for SIGA-270 series (USA ONLY)	
276-GLR	20 Glass Rods - for SIGA-278 series	
276B-RSB	Surface Mount Box, Red - for SIGA pull stations	1 (0.6)

Intelligent Smoke Detector

SIGA-OSD



Overview

The Signature Optica Series **SIGA-OSD** smoke detector brings advanced optical sensing technology to a practical design that increases efficiency, saves installation time, cuts costs, and extends life safety and property protection capabilities. Continuous self-diagnostics ensure reliability over the long-haul, while environmental compensation helps reduce maintenance costs.

Like all Signature Optica Series detectors, the **SIGA-OSD** is an intelligent device that gathers analog information from multiple optical sensors, converting this data into digital signals. Utilizing dual optical wavelengths combined with multiple detection angles, the **SIGA-OSD** differentiates particles that are not representative of actual smoke. Particle data is input into digital filters which feed a series of ratios removing signal patterns that are typical of nuisance sources, thus reducing unwanted alarms. To make an alarm decision, the detector's on-board microprocessor measures and analyzes all optical sensor readings and compares this information to preprogrammed settings.

Standard Features

- Multi-criteria optical smoke sensing technology
- Wide 0.5 to 4.36 %/ft. (1.6 to 13.6 %/m) smoke obscuration
- Uses Existing Wiring
- Integrated nuisance rejection reducing unwanted alarms from general cooking particulates
- Listed to UL 268 7th edition
- Automatic Device Mapping
- Up To 250 Total Signature Addresses Per Loop
- Two Levels of Environmental Compensation
- Two Levels of Dirty Detector Warning
- Twenty Pre-Alarm Settings
- Five Sensitivity Settings
- Non-Volatile Memory
- Electronic Addressing
- Automatic Day/Night Sensitivity Adjustment
- Bicolor (Green/Red) Status LED
- Standard, Relay, Fault Isolator, and Audible Mounting Bases
- Sensor Markings Provide Easy Testing Identification

Note: Some features described here may not be supported by all control systems. Check your control panel's Installation and Operation Guide for details.

Application

The **SIGA-OSD** detects particles from a wide range of combustion sources and will trigger an alarm when smoke density in the chamber reaches preprogrammed level. Thanks to its high-performance reflective response technology, the smoke sensor responds quickly and reliably to a wide range of fire types, including both fast and slow burning fires fueled by combustibles typically found in modern multi-use buildings.

Compatibility

The **SIGA-OSD** detector is compatible only with control panels using a Signature Loop controller.

Installation

Signature Series detectors mount to North American 1-gang boxes, 3-1/2 inch or 4 inch octagon boxes, and to 4 inch square electrical boxes 1-1/2 inches (38 mm) deep. They mount to European BESA and 1-gang boxes with 60.3 mm fixing centers. See mounting base installation and wiring for more information.

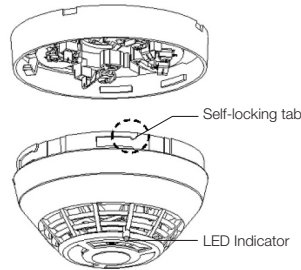

Sensing and reporting technology

The microprocessor in each detector provides additional benefits – Self-diagnostics and History Log, Automatic Device Mapping, and Fast, Stable Communication.

Self-diagnostics and History Log - Each Signature Series detector constantly runs self-checks to provide important maintenance information. The results of the self-check are automatically updated and permanently stored in the detector's non-volatile memory

Automatic Device Mapping - The loop controller learns where each device's serial number address is installed relative to other devices on the circuit. The mapping feature provides supervision of each device's installed location to prevent a detector from being reinstalled (after cleaning, etc.) in a different location from where it was originally.

Fast Stable Communication - On-board intelligence means less information needs to be sent between the detector and the loop controller. Other than regular supervisory polling response, the detector only needs to communicate with the loop controller when it has something new to report.

Testing & Maintenance

Each detector automatically identifies when it is dirty or defective and causes a "dirty detector" message. The detector's sensitivity measurement can also be transmitted to the loop controller. A sensitivity report may be printed to satisfy NFPA sensitivity measurements, which must be conducted at the end of the first year and every two years thereafter.

The user-friendly maintenance program shows the current state of each detector and other pertinent messages. Single detectors may be turned off temporarily from the control panel. Availability of maintenance features is dependent on the fire alarm system used.

Accessories

Detector mounting bases have wiring terminals that are accessible from the "room-side" after mounting the base to the electrical box. The bases mount to North American 1-gang boxes and to 3½ inch or 4 inch octagon boxes, 1½ inches (38 mm) deep. They also mount to European BESA and 1-gang boxes with 60.3 mm fixing centers. The SIGA-SB4, SIGA-RB4, and SIGA-IB4 mount to North American 4 inch sq. electrical boxes in addition to the above boxes. They include the SIGA-TS4 Trim Skirt, which is used to cover the "mounting ears" on the base. The SIGA-AB4G mounts to a 4 inch square box only.

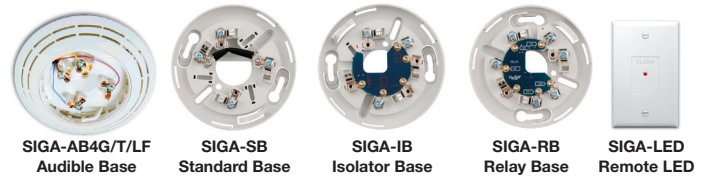

Remote LED SIGA-LED - The remote LED connects to the SIGA-SB or **SIGA-SB4** Standard Base only. It features a North American size 1-gang plastic faceplate with a white finish and red alarm LED.

SIGA-TS4 Trim Skirt - Supplied with 4 inch bases, it can also be ordered separately to use with the other bases to help hide surface imperfections not covered by the smaller bases.

Sounder Bases - Signature Series sounder bases are designed for use where localized or group alarm signaling is required.

- **SIGA-AB4G** bases provide sounder capability to Signature Series to heat and smoke detectors. They are not intended for use with combination carbon monoxide detectors in Fire-plus-CO mode.
- **SIGA-AB4GT** bases provide sounder capability to Signature Series smoke and heat detectors, as well as carbon monoxide detectors when used with a SIGA-TCDR Temporal Pattern Generator.
- **SIGA-AB4G-LF** bases provide 520 Hz low frequency sounder capability to Signature Series smoke and heat detectors, as well as carbon monoxide detectors when used with a SIGA-TCDR Temporal Pattern Generator. The SIGA-AB4G-LF is suitable for applications requiring low frequency audible tones.

Typical Wiring

The detector mounting bases accept #18 AWG (0.75mm²), #16 (1.0mm²), #14 AWG (1.5mm²), and #12 AWG (2.5mm²) wire sizes. Sizes #16 AWG (1.0mm²) and #18 AWG (0.75mm²) are preferred for ease of installation.

Standard Detector Base, SIGA-SB, SIGA-SB4

This is the basic mounting base for EDWARDS Signature Series detectors. The SIGA-LED Remote LED is supported by this Base.

Term	Description
1	Not Used
2	DATA IN/OUT (+)
3	Not Used
4	DATA IN (-)
5	Remote LED (+)
6	Remote LED (-)
7	DATA OUT (-)

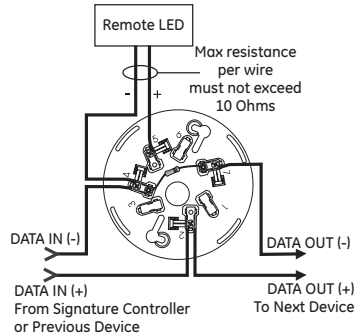

Isolator Detector Base, SIGA-IB, SIGA-IB4

This base includes a built-in line fault isolator for use on Class A circuits. A detector must be installed for it to operate. The isolator base does not support the SIGA-LED Remote LED.

The isolator operates as follows:

- a short on the line causes all isolators to open within 23 msec.
- at 10 msec intervals, beginning on one side of the Class A circuit nearest the loop controller, the isolators close to provide the next isolator down the line with power.
- when the isolator next to the short closes, it reopens within 10 msec.

The process repeats beginning on the other side of the loop controller.

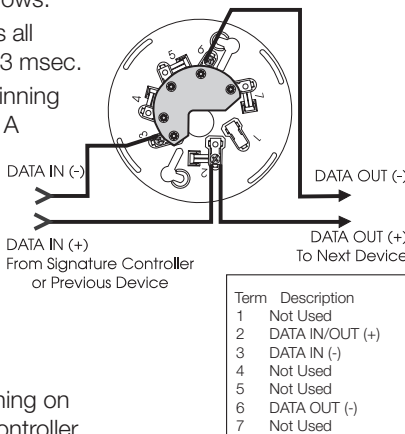

Relay Detector Base, SIGA-RB, SIGA-RB4

This base includes a relay. Normally Open or Normally Closed operation is selected during installation. The dry contact is rated for 1 amp (pilot duty) @ 30 Vdc. The relay's position is supervised to avoid accidentally jarring it out of position. The SIGA-RB can be operated as a control relay if programmed to do so at the control panel. The relay base does not support the SIGA-LED Remote LED.

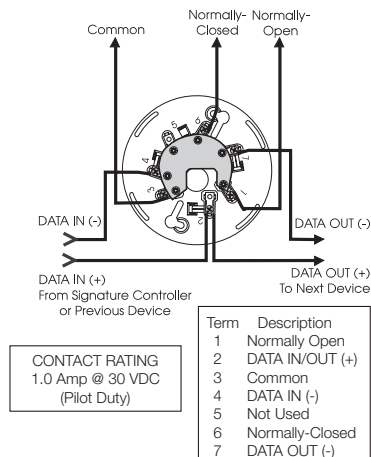

Audible Sounder Bases, Fire Mode

AB4GT, AB4G, AB4G-LF sounder bases

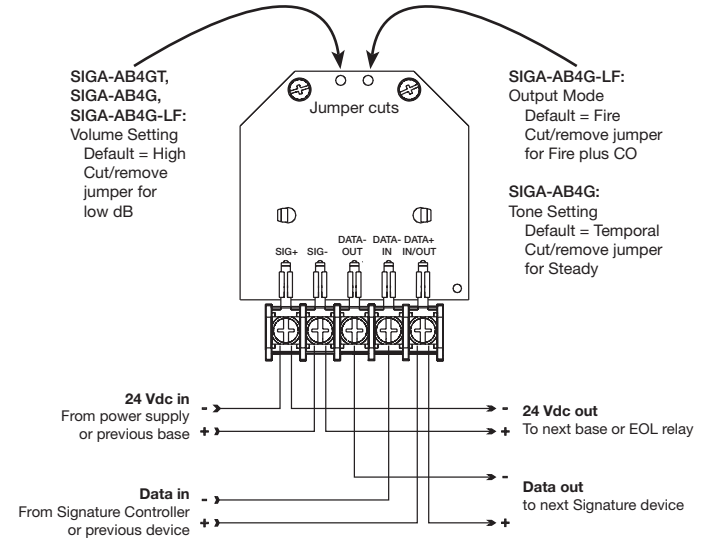

Warnings & Cautions

- This detector does not operate without electrical power. As fires frequently cause power interruption, discuss further safeguards with the local fire protection specialist.
- This detector does not sense fires in areas where smoke cannot reach the detector. Smoke from fires in walls, roofs, or on the opposite side of closed doors may not reach the detector.
- In Canada, install according to CAN/ULC-S524 Standard for the Installation of Fire Alarm Systems, CSA C22.1 Canadian Electrical Code, and the local authority having jurisdiction.



LIFE SAFETY & INCIDENT MANAGEMENT

Contact us...

Phone: 800-655-4497, Option 1
 Fax: 866-226-2126
 Email: Edwards.techsupport@fs.utc.com
 Website: <https://www.edwardsfiresafety.com/>

8985 Town Center Pkwy
 Bradenton, FL 34202

EDWARDS is a registered mark in the United States and other countries.

© 2019 United Technologies Corporation.
 All rights reserved.

Dimensions

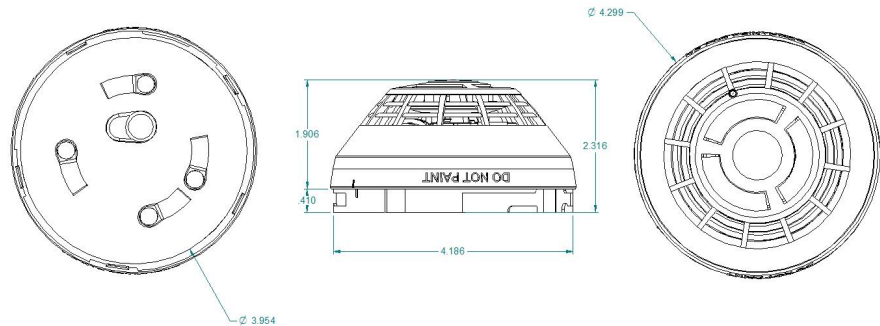

Specifications

Operating voltage	15.20 to 19.95 VDC
Normal operating current	32 μ A
Alarm current	45 μ A
Smoke Sensitivity Range	UL/ULC: 0.5 to 4.36 %/ft. (1.6 to 13.6 %/m) obscuration
Vibration level	10 to 35 Hz, with an amplitude of 0.01 in.
Air velocity	0 to 4,000 ft./min (0 to 20 m/s)
Wall mounting	12 in. (305 mm) max. from ceiling
Compatible bases	See Ordering Information
Compatible detector testers	Testifire 1000, Testifire 2000
Operating environment	32 to 120°F (0 to 49°C), 0 to 93% RH, noncondensing
Construction	High Impact Engineering Polymer, White
Storage temperature	-4 to 140°F (-20 to 60°C)
Environmental compensation	Automatic
Agency Listings	CAN/ULC-S529, UL 268-7, UL 268A

Ordering Information

Catalog Number	Description	Ship Wt. lbs (kg)
SIGA-OSD	Intelligent Optical Smoke Detector	0.4 (0.16)

Accessories		
SIGA-SB	Detector Mounting Base - Standard	
SIGA-SB4	4-inch Detector Mounting Base c/w Trim Skirt	
SIGA-RB	Detector Mounting Base w/Relay	
SIGA-RB4	4-inch Detector Mounting Base w/Relay, c/w Trim Skirt	0.2 (.09)
SIGA-IB	Detector Mounting Base w/Fault Isolator	
SIGA-IB4	4-inch Detector Mounting Base w/ Fault Isolator, c/w Trim Skirt	
SIGA-LED	Remote Alarm LED (not for EN54 applications)	
SIGA-AB4G	Audible (Sounder) Base for Fire Detectors	0.3 (0.15)
SIGA-AB4G-LF	Low Frequency Audible (Sounder) Base for CO and/or Fire Detectors	0.3 (0.15)
SIGA-AB4GT	Audible (Sounder) Base for CO and/or Fire Detectors	0.3 (0.15)
SIGA-TS4	Trim Skirt (supplied with 4-inch bases)	0.1 (0.04)
SIGA-TS	Trim Skirt - (optional for non 4-inch bases)	0.1 (0.04)
SIGA-DMP	Detector Mounting Plate	3.0 (1.4)
SIGA-RTA	Detector Removal Tool	
SIGA-VA	Detector Cleaning Tool	

LIFE SAFETY & INCIDENT MANAGEMENT

EST4

Emergency Communications Platform



Overview

EST4 is the premier emergency communications system from EDWARDS. Though it represents a small change in name from its predecessor, EST4's leap forward in capability is anything but diminutive. This exciting flagship system features a whole new network architecture that makes fire alarm, mass notification, and building integration easy to implement, quick to service, and secure in the face of today's cyberthreats.

From its thoughtfully-crafted interface to its advanced connectivity and extensive system capacity, **EST4** demonstrates that form and function are inseparable elements of good system design. It provides systems engineers with the tools they need to create projects that exceed expectations and have plenty of room to grow, all while respecting facility budgets and construction schedules. The net result is an emergency communications system equally suited to new and retrofit projects; a platform that keeps property safe and steers people clear of danger.

Features

- Investment-forward Platform Designed for the Future**
 Protects the past with backwards compatibility for EST3 retrofits, flexible feature set.
- On-board Webserver**
 Remote device-independent access to system status reports.
- Built-in E-mail and E-mail-to-SMS Messaging**
 Instant notification of specific event types sent to appropriate personnel.
- Large Full-color LCD Touch Screen with Tactile Buttons**
 Fast, intuitive access to service and responder functions.
- Five-color LED Indicators**
 System status at a glance, select the color needed during programming, reduces replacement part inventory, maximizes use of available infrastructure.
- Network data, audio data, and telephone data share a single twisted pair or single fiber strand**
 Up to 75 percent less cabling, substantial cost savings in material and labor.
- Backwards Compatibility with EST3**
 Wiring, devices, and most local rail modules are backward compatible, providing easy migration paths, economical transition to new technology.
- Existing Systems Supporting only Network Data can also Support Voice Audio**
 Upgrades add value and extend capabilities in retrofit situations.

continued on next page...

Application

From the moment the control panel is powered up it is apparent that **EST4** is designed for ease of use. Its powerful user interface bears this out by allowing operators to use the system with a level of fluidity that naturally guides them through high and low level system operations with efficiency and confidence.

EST4 does this by combining the simplicity of color LCD touchscreen technology with at-a-glance programmable color display strips and tactile direct-access control buttons.

These input points, together with meticulously-engineered responder and service functionality, allow **EST4's** interface to provide clear navigation paths, instant-access shortcuts, and context-sensitive display screens. This means that responders have quick access to vital system event information and control functions, while service personnel can dive deeply into system programming unencumbered by complicated operational routines.

EST4's LCD large touch-screen display is the window into system operation and maintenance functions. It is large enough to support a graphical tree view of the system. The tree closely matches the system's physical layout, so there's no need for look-up tables to find specific devices. This is invaluable to technicians and building service personnel who can pinpoint the location of an off-normal device with a glance at the on-screen tree.

The **EST4** LCD is capable of displaying 262,144 colors, **EST4's** LCD display screen will display eight events without scrolling. In addition to touch-screen capability, the display assembly includes four dedicated easy-access rubber buttons for control functions most needed for emergency response.

Up to 576 tactile switches and 576 LED indicators may be mounted in a single **EST4** cabinet for control and annunciation purposes. Control Display Modules (CDMs), comprise a column of programmable buttons accompanied by one or two LED indicator positions per button. Indicator-only modules comprise up to 24 indicators. Switch and indicator module LEDs can be set to any of five colors, providing an additional level of feedback.

Print-anywhere slide-in label inserts give control/display strips context with color-coded shading and other effects. They can be localized for regional language requirements, and printed on-the-fly to accommodate system changes as they are implemented.

Remote access and notification

System access to **EST4** doesn't end when the cabinet door swings shut. A webserver in each **EST4** panel allows authenticated users to gain access to day-to-day reporting. **EST4** webservices are device-independent and support all major browsers on PC and MAC operating systems, including mobile platforms – without the need for special apps or other software. Users can log into the secure **EST4** webserver and run system reports. Like any web page, system reports can be copied, printed, saved, and e-mailed. The system report data can also be saved in XML form and used in external spreadsheet applications for further processing.

EST4 keeps up with the fast pace of mobile computing with its built-in e-mail services and e-mail-to-text-message capabilities. These ensure that key personnel receive instant notification of relevant changes of system state. Technicians can be dispatched to the site within minutes of a service event, while safety and security personnel can arrive concurrently with first responders should the system go into alarm.

Networking

Supporting these important interface developments is a robust system underpinned by solid networking and exceptional security. Thanks to its self-configuring network, **EST4** easily deploys and configures without intervention by network administration personnel. It adapts to a wide range of network configurations, including rings, stars, redundant segment, and full mesh topology. The network even allows changes in the physical layer from copper to fiber, and employs hot-swappable network connections at control panels and annunciators. All this improves network reliability and saves money at installation time and throughout the equipment's life cycle.

The advanced technology behind **EST4's** network is powerful enough

to drive the biggest installations viable today. It pushes wire runs into miles, and addressable points into the many of thousands. A single IPv6 or mesh network, for example, can support copper wire runs of nearly a mile between nodes puts detection, alarm, notification, and audio into the furthest reaches of the tallest buildings and broadest campuses. Fiber optic cable handles multiple miles between nodes, while carrying all system data on a single fiber strand.

Features (continued from page 1)

- **Self-configuring Network**
No intervention by system admin personnel required.
- **Hot Swappable Network Connections**
Change from copper to fiber with no system down-time.
- **480 Mbps USB Ports on Panels**
Fast configuration updates, local printing.
- **Advanced Upload/download Protocol**
No system down-time during updates.
- **Firewalls meet the latest Advanced Encryption Standards**
Front-line defense against threats carried by outside networks. NIST - AES Validation #4806.
- **Extended Paging Groups**
Audio reaches occupants based on location and movement.
- **Local and Remote Reporting**
Generate reports on-site, at system printers, or remotely via webserver.
- **20,000-event History**
Invaluable timeline data for service and investigative purposes.
- **Cabinet Doors may be used for Nodes and Annunciators**
Cabinet Doors may be used for Panels and Annunciators giving a consistent appearance, fewer cabinet parts.

Riser Diagram

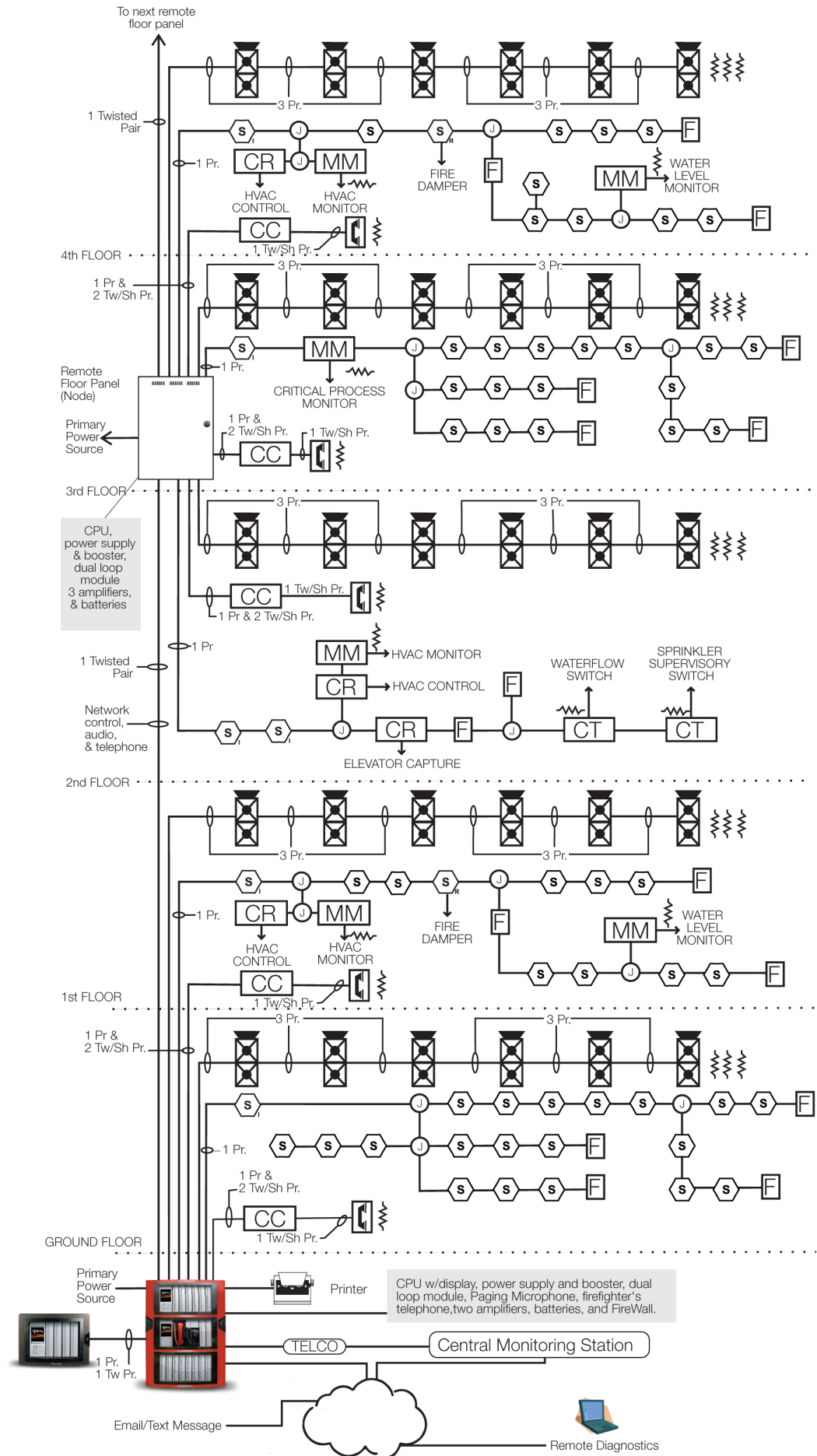

System design benefits greatly from this huge capacity. Minimal cabling requirements take scalability a step further. With EST4 a single copper pair or single fiber supports panel network data, audio data, as well as telephone data. This cuts cable counts by up to 75 percent. Meanwhile, multiple firefighter's telephones risers are accommodated on the network, which allows them to be deployed at much further distances compared with analog audio transmission methods.

Reduced network cabling not only boosts system efficiency by requiring fewer physical connections, it also saves money by reducing material and labor costs. This means that new EST4 installations benefit from lower cable counts, while retrofits may be able to be upgraded to support audio and telephones without the need to pull additional cable.

For new installations EST4 delivers flexibility. It can use twisted pair wire, Multi-mode fiber, Single Mode fiber, and even CAT5 cable. In fact CAT5 is not restricted to Class N applications. It also meets the stringent requirements of Class A, Class B, and Class X. When using CAT5, distances are not limited to 328 ft. (100 m). EST4's CAT5 support includes a solution that allow up to 3,280 ft. (1 km) of cable length.

Cybersecurity

The security and integrity of the EST4 network is paramount to its ability to maintain systems operations in the face of outside threats. The most vulnerable point of contact for any integrated building system is where it meets the facility owner's existing TCP/IP network. Ironically it is this gateway, which enhances and expands system capability beyond the communications network, that also exposes the system to some of its most critical vulnerabilities.

To combat outside threats, every EST4 panel can deploy proxy firewalls that effectively insulate the internal fire network from external Intranet or internet connections and the malware, ransom ware, and denial-of-services attacks that may be raging beyond. The EST4 proxy firewall uses Advanced Encryption Standard (AES) encryption and secure protocols making it FIPS Pub 197 certified. The FIPS, Federal Information Processing Standards, are the most current and most advanced encryption protocols administered by the National Institute of Standards and Technology (NIST).

EDWARDS recommends the installation of robust commercial firewall between the facilities intra-net and the Internet. To further enhance network security, an optional tamper switch may be installed on EST4 cabinet doors. This alerts the system when equipment enclosures are accessed.

Programming

EST4 is an open book for authorized programmers. Configuration data travels in both directions: it can be downloaded to the panel and uploaded to a laptop. This two-way movement of configuration files allows technicians to upload and backup programming before making changes to the system. By doing so, the tech ensures that trustworthy restore points are available at all times. Also, should the building owner change service companies, up-to-date system programming data can be retrieved with proper authorization, from the panel by the new maintenance personnel in minutes.

Adding to the integrity of panel configuration is an advanced data transfer routine that does not compromise or interrupt normal system operation. This keeps the system fully functional during configuration data exchange – logging events and executing programming during the entire process.

EST4's high-performance Configuration Utility (CU) depicts the system in a graphical tree view, which matches the system's physical layout. This provides a familiar format in which to find programming for specific devices, and also does away with the need for look-up lists when, for example, devices need to be taken out of service because of site specific activities. The programming tool also features a context-sensitive Intellisense rule editor, which checks for syntax and semantic programming errors in real time.

The EST4 Configuration Utility (CU) also makes short work of configuration downloads to the control panel. It does this through a single firmware download for all modules, and a single database download for all node databases.

EST4's on-board USB ports also make it easy to connect with external devices. The USB ports do away with special cables and RS232-to-USB conversion dongles. It allows direct high-speed connection with laptops for the exchange of configuration data at transfer rates of up to 480 Mbps. Printers can be connected to panels or remote annunciators for on-site event and report printouts.

Audio

Nothing informs building occupants better than the spoken word, and EST4's highly intelligible voice audio ensures that those words are heard loud and clear. This high fidelity messaging, across EST4's impressive capacity of 100 channels, provides the flexibility that responders need to get messages out clearly and concisely.

EST4 live paging capabilities ensure that those messages reach the right people at the right time. In addition to standard paging functions (Page to Evacuation, Page to Alert, All Call, and All Call Minus), EST4 introduces Page to Other and Page to Emergency.

Page to Other is a quick way to reach people in stairwells and elevators, while Page to Emergency is for Mass Notification purposes. This added live paging capability allows responders to reach occupants based not only on their proximity to danger, but also based on their potential to move inadvertently towards specific danger points.

EST4 live paging also lets responders select individual paging groups as well as combinations of groups. This allows them to reach people in Alert and Evacuation zones simultaneously without having to page one group, and then page the other.

Reporting System Snapshots

EST4 can generate an abundance of stock reports, and users may also design their own within the configuration utility. Printed reports can be generated locally at any control panel, node, or annunciator. Familiar USB connections allow for quick uploading to laptops or transfer to locally-connected printers. Reports can also be sent from any of these locations to system printers elsewhere on the network.

EST4 allows the selection of report data right down to the device level by means of pre-built templates, custom reports, or even on-the-fly using the CU configuration tool. Report content is information rich, detailed, and meaningful. This meticulous report formatting and organization results in highly understandable system overviews and useful deep dives into underlying system configuration data.

Event History Timelines

While system status reports are invaluable for generating snapshots of important data, EST4's event history can paint a vivid picture of the system over time. A giant 20,000-event repository comprises EST4's history, which could span back as far as the system's commissioning. Half of the history can be set aside exclusively for Alarms, ensuring that records of the most important events are preserved. To support forensic investigations, up to 10,000 events can be locked and preserved so as not to be overwritten.

A large variety of pre-built history reports are available for quick access to vital records filtered by day, week, month or year. Custom reports help pinpoint records by date, time, location, device type and more. Together EST4's large history capacity and flexible history reporting serve to create vital timelines that aid in system maintenance and forensic investigations.

Value-added Forward Migration

Easy migration paths ensure an economical transition from EST3 platforms to EST4's next-generation technology. To start, configuration data is easily transferable from an existing EST3 project to an EST4 upgrade. Hardware is also easy to migrate: all Signature Series devices, modules, and service tools are fully supported by EST4, as are Genesis series notification appliances – no rewiring is required.

Existing network cabling is also reusable for upgrades. EST4 even supports network messaging plus live paging with legacy wiring. In fact, simple twisted pair wiring, previously useable only for panel-to-panel data communications can, with EST4, support panel data, paging, as well as telephone. This means that voice audio capability may be added to a system originally wired only for network panel to panel communications – without pulling any additional wire.

EST4 also employs EST3 power supplies, audio amplifiers, MNEC equipment, CAB Series wallboxes, and most local rail modules. This makes the move to EST4 a cost-effective choice for existing installations, and new projects alike. It is a move that will benefit system efficiency and scalability now and for many years into the future.

Agency Approvals

UL864 10th edition - UOJZ, UUKL, SYZV, UOQY

UL2017 2nd edition - FSZI

UL2572 2nd edition - PGWM

ULC-S527-11 3rd edition - UOJZ, UULK7, SYXV7

ULC-S576-14 1st edition - PGWM7

ULCS-S559-13 2nd edition - DYR7



LIFE SAFETY & INCIDENT MANAGEMENT

Contact us

Phone: 800-655-4497 (Option 4)

Email: edwards.fire@carrier.com

Website: edwardsfiresafety.com

8985 Town Center Pkwy
Bradenton, FL 34202

© 2020 Carrier
All rights reserved.



LIFE SAFETY & INCIDENT MANAGEMENT

EST4 Remote Annunciators

4-xxANN Series

4-2ANN and 4-4ANN shown with optional equipment.



NYC FIRE DEPT.
COA # 6314



7120-1657:
0509

Overview

EST4 Remote Annunciators provide front panel system status and control functions located conveniently anywhere on the EST4 network. Annunciators can be as simple as a couple of LED indicator strips, or complex enough to support up to two LCD displays, an audio telephone interface, and hundreds of control points and indicators — all in a single enclosure.

Up to 576 tactile switches and 576 LED indicators may be mounted in a single EST4 annunciator cabinet. Control Display Modules (CDMs), comprise a column of programmable buttons accompanied by one or two LED indicator positions per button. Indicator-only modules hold up to 24 indicators. Switch and indicator module LEDs can be set to any of five colors, providing an additional level of feedback.

All remote annunciators feature color-matched cabinets and distinctive metallic bronze (Pantone Coated PMS# P 171-16 C, Pantone RGB# 81 75 67, and RAL Classic/RAL Design# 7022) doors for a readily-identifiable and consistent look throughout the facility.

Thanks to EST4's ingenious communications protocol, network data — as well as telephone and audio data — is carried on a single fiber optic cable or twisted wire pair. This multi-use capacity has an enormous cost-savings potential compared with conventional audio transmission, reducing not only installation costs, but also simplifying ongoing system maintenance.

Slide-in LED and switch labeling makes it easy to incorporate right into the annunciator design such information aids as descriptive text, color-coding, icons, and local languages. For custom floorplans or facility maps, EST4 offers LED driver boards perfectly suited to operate in most graphic annunciators.

Standard Features

- **Connection Over High-speed Life Safety Network**
Annunciator network and audio data carried on a single fiber or twisted pair.
- **Optional Color LCD Display**
Touch screen capability supplements control buttons for quick, intuitive access to key system status and control functions.
- **Wide Range of Annunciator Configurations**
From a two-slot model holding a single LCD display to 24-slot cabinets for complex annunciation.
- **Supports Two LCD Displays**
Providing users with a simplified sequence of operations.
- **Convenient Programming**
Built-in support for radio groups of up to 24 switches in size.
- **Slide-in Switch and Indicator Labels**
A simple, effective means to customize annunciator appearance and messaging.
- **Programmable LED Flash Rates and Colors**
Easy to see, quick to understand.
- **Clean and robust door designs**
- **Support for all Common Networking Media**
Annunciators connect over any combination of twisted pair wire, Multi-mode fiber, Single Mode fiber, and even CAT5 cable.

Application

Use EST4 remote annunciators where a compact system status display is needed. Annunciator configuration can range from a couple of LED indicator strips, to complex arrangements supporting in a single enclosure up to two LCD displays, paging microphone, firefighter telephone and hundreds of control points and indicators.

EST4 annunciators support a range of options that make them ideal for Mass Notification, Life Safety and other emergency communications purposes. They can be used as Central Control Stations (CCS), Autonomous Control Units (ACU), Local Operating Console (LOC), and combination units from which initiated Mass Notification functions can be controlled.

Cabinets may be surface or semi-flush mounted for installation expediency and aesthetic appeal.

Annunciators connect over the high-speed EST4 network, which supports copper or fiber-optic communications in any combination. Network data and audio data share the same cabling. This results in more efficient deployment with fewer cables needed and fewer connections to be made.

The 2 wide, 4 wide, and 6 wide, 4-xANNMT series, annunciator wallboxes come standard with surface mounting trims and semi-flush mounting trims.

The 8 space, 16 space and 24 space 4-xxANNMT series wallboxes are designed for surface mount applications. Their depth is kept to a minimum to allow the least amount of room penetration. When semi-flush mounting is required, order the standard 3-CAB5B, 7B, or 14B wallbox.

Engineering Specification

The Life Safety system shall incorporate annunciation of Alarm, Supervisory, Trouble and Monitor operations. Annunciation must be through the use of both LED display strips complete with a means to custom label each LED as to its function. LED color shall be selectable at configuration time. Where applicable control switches must be provided. Switches with LEDs must provide positive feed back to the operator of remote equipment status. A color touchscreen LCD display with basic common control LEDs and switches shall be provided. Optionally a second color touchscreen display may be added to support audio and telephone operations. The Common Control Switches and LEDs provided as minimum will be: Reset switch and LED, Alarm Silence switch and LED, Panel Silence switch and LED, Drill switch and LED. It must be possible to add additional common controls as required through the use of modular display / control units. The LCD must provide the emergency user, hands free viewing of the first highest priority event. System events must automatically be placed in queues. It shall be possible to view specific event types separately. The total number of active events by type must be displayed. It must be possible to customize the designations of all user interface LEDs and switches for local language requirements. It must be possible to route system event messages to specific annunciator locations. It must be possible for the annunciator to contain a paging microphone and fire fighter telephone.

Installation and Mounting

4-2ANNMT, 4-4ANNMT, and 4-6ANNMT included side trim installation for surface mount applications

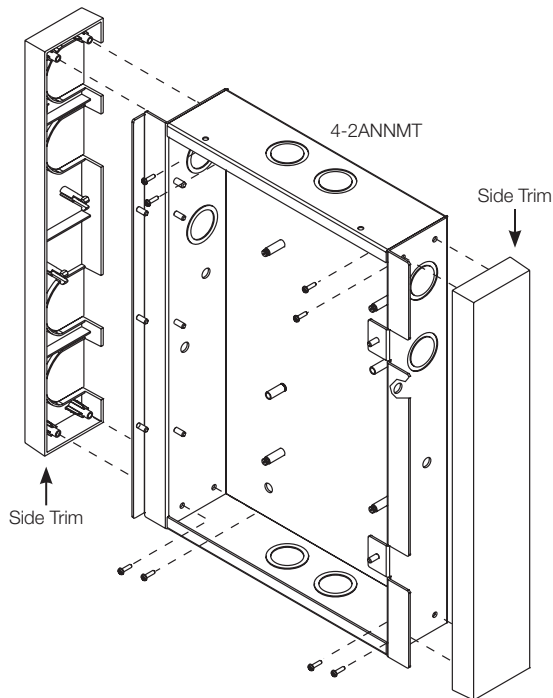

4-2ANNMT, 4-4ANNMT, and 4-6ANNMT included trim installation for semi-flush mount applications

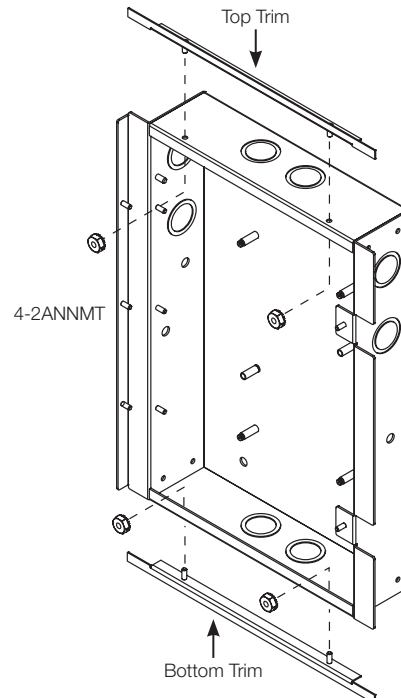

See Specifications Table for 4-8ANNMT, 4-16ANNMT, 4-24ANNMT mounting options.

Dimensions, wallboxes

4-2ANNMT Wallbox Assembly, Surface and Semi-flush Mounting (both trims are included)

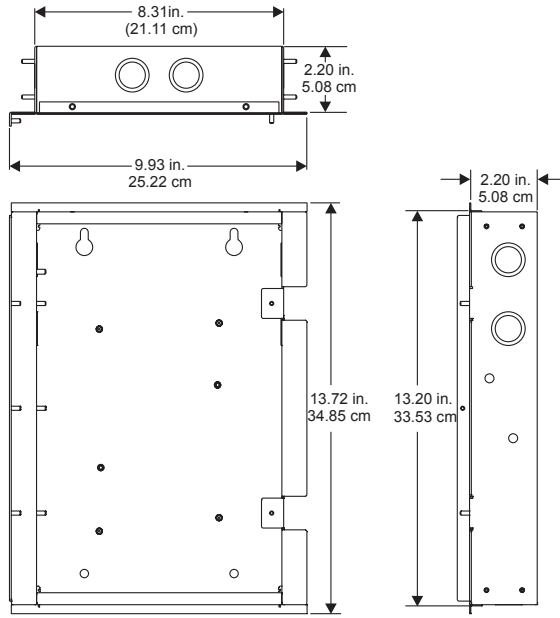

Semi-flush mount (trim installed top and bottom)

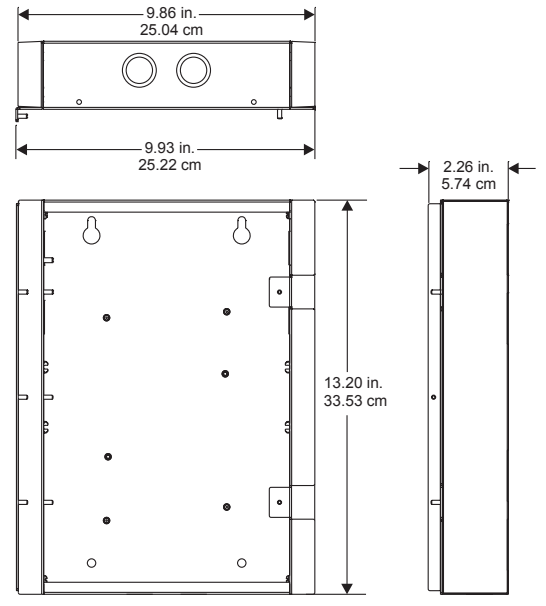

Surface mount (trim installed right and left sides)

4-4ANNMT Wallbox Assembly, Surface and Semi-flush Mounting (both trims are included)

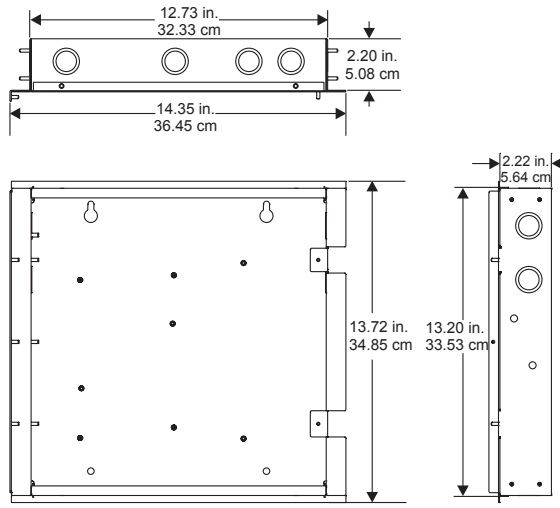

Semi-flush mount (trim installed top and bottom)

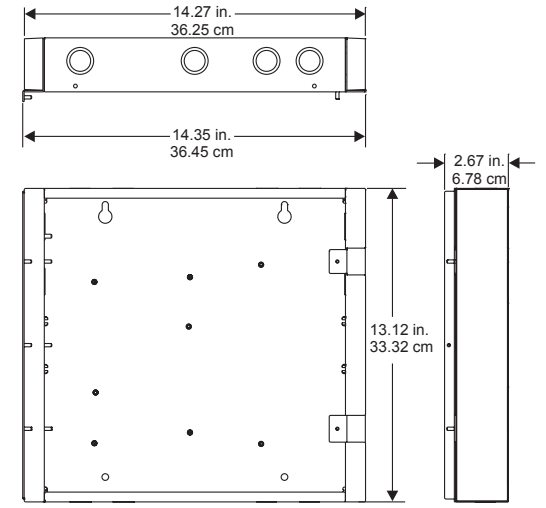

Surface mount (trim installed right and left sides)

4-6ANNMT Wallbox Assembly, Surface and Semi-flush Mounting (both trims are included)

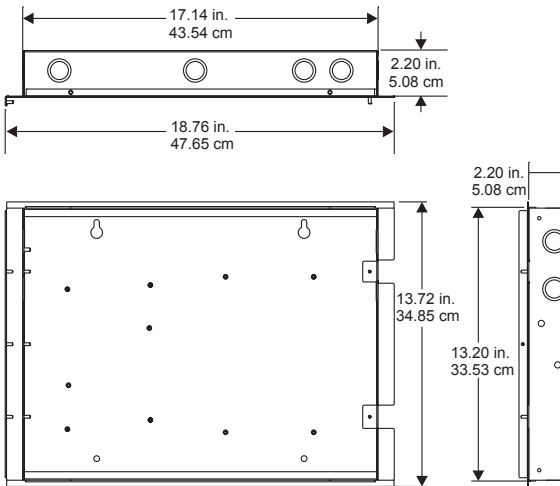

Semi-flush mount (trim installed top and bottom)

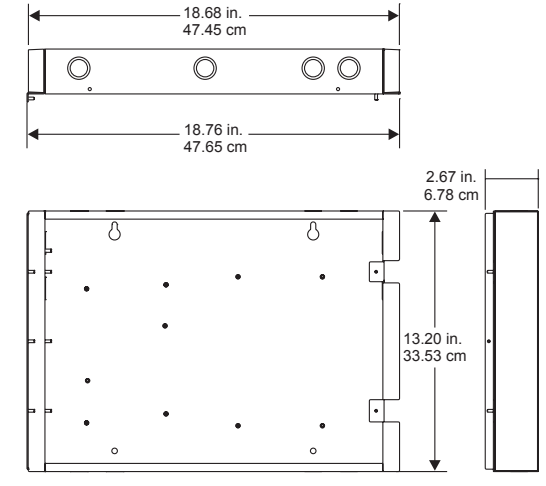

Surface mount (trim installed right and left sides)

Dimensions, wallboxes

4-8ANNMT Wallbox Assembly, Surface Mount

For semi-flush mounting, use a 3-CAB5B wallbox.

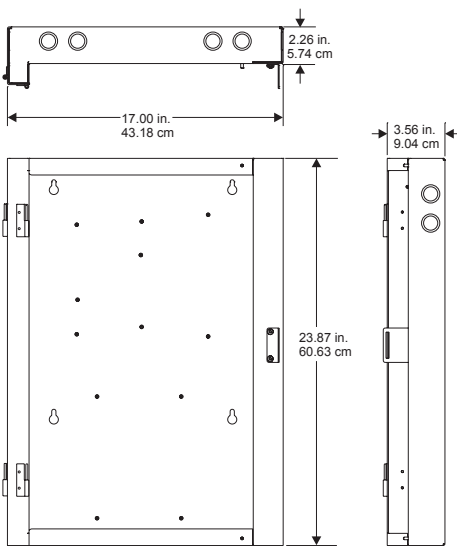

4-24ANNMT Wallbox Assembly, Surface Mount

For semi-flush mounting, use a 3-CAB14B wallbox.

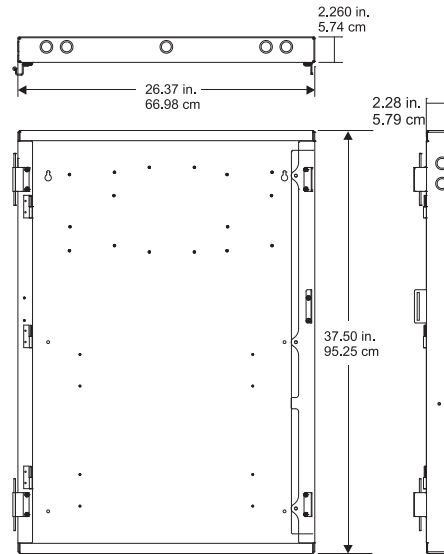

4-16ANNMT Wallbox Assembly, Surface Mount

For semi-flush mounting, use a 3-CAB7B wallbox.

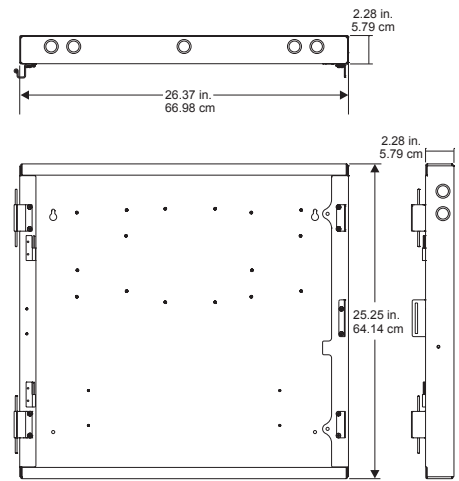

Dimensions, door assemblies

4-2ANN Series Door Assembly

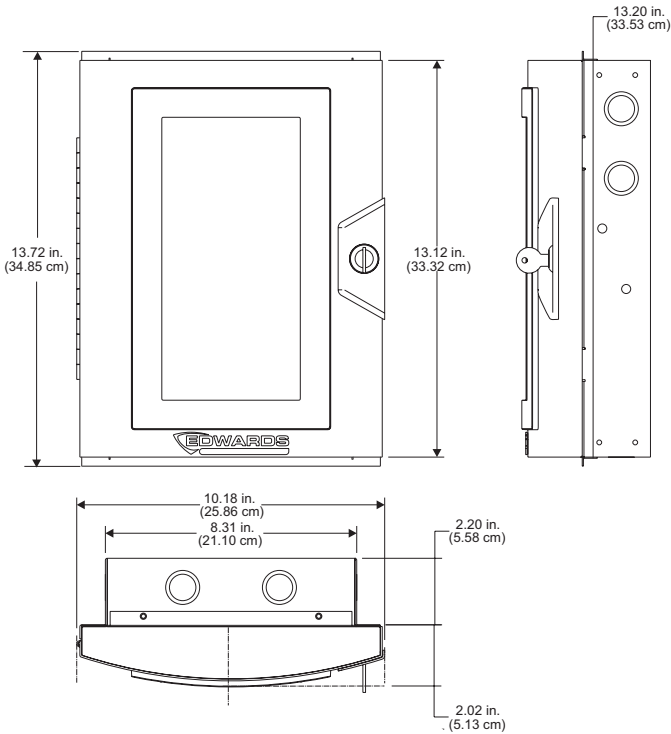

4-4ANN Series Door Assembly

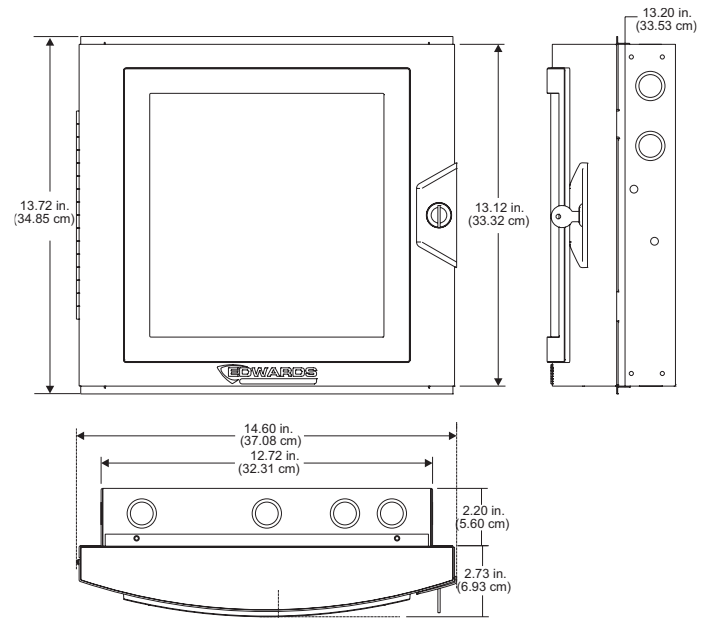

Dimensions, door assemblies continued

4-6ANN Series Door Assembly

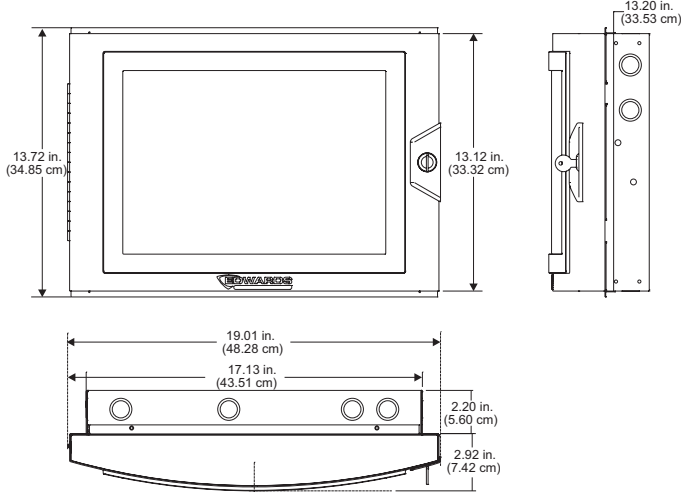

4-CAB24D Series Door Assembly

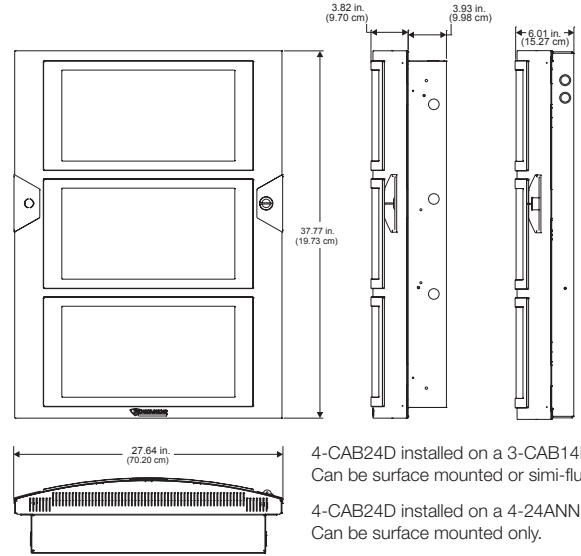

4-CAB24D installed on a 3-CAB14B wallbox.
Can be surface mounted or semi-flush mounted.

4-CAB24D installed on a 4-24ANNMT wallbox.
Can be surface mounted only.

4-CAB8D Series Door Assembly

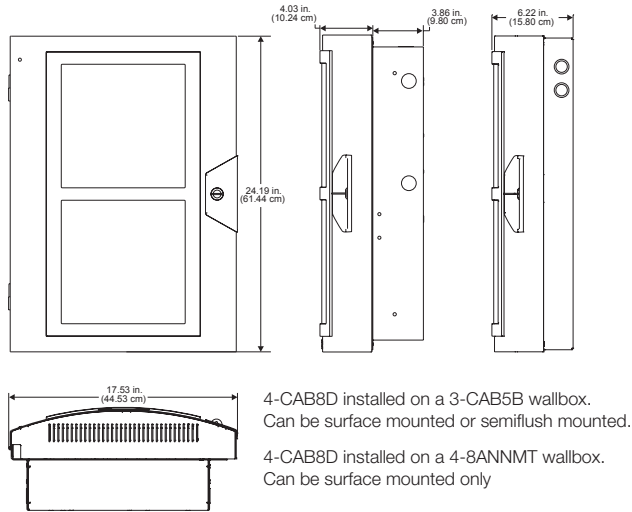

4-CAB8D installed on a 3-CAB5B wallbox.
Can be surface mounted or semiflush mounted.

4-CAB8D installed on a 4-8ANNMT wallbox.
Can be surface mounted only.

4-CAB16D Series Door Assembly

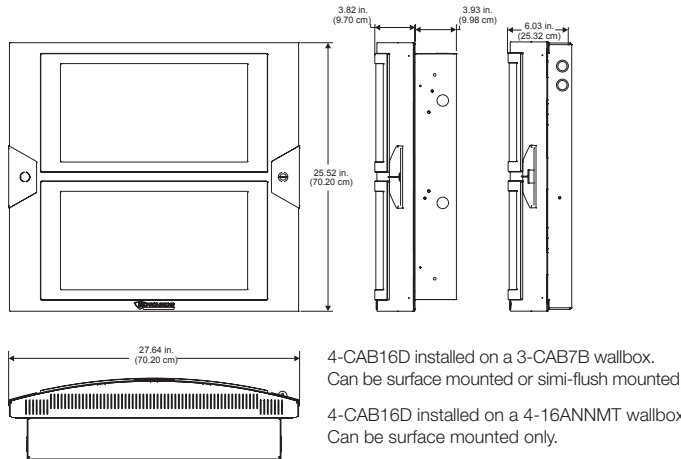

4-CAB16D installed on a 3-CAB7B wallbox.
Can be surface mounted or semi-flush mounted.

4-CAB16D installed on a 4-16ANNMT wallbox.
Can be surface mounted only.

Wiring

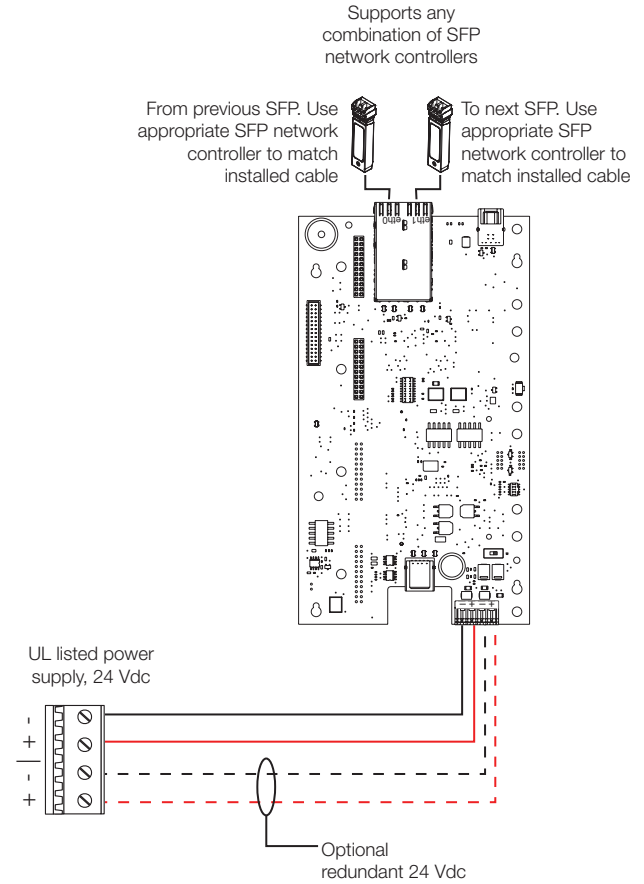

SFP Network Controllers

Model #	Description	Network Interconnection Media Supported
4-NET-CAT	100 Mbps SFP Network Controller	Cable type - Cat 5e or better Connector type - RJ-45 Distance 328 ft. (100 m) max
4-NET-MM	Multi-mode fiber-optic SFP Network Controller	SFP network media interface, multi-mode fiber-optic, supports 50/125 μ (OM3/OM4) fiber pair up to 1.24 mi. (2 km), 62.5/125 μ (OM1) fiber pair up to 0.62 mi. (1 km), or a 100/140 μ fiber pair up to 150 m. Order one 4-NET-MM for "in" wiring and one for "out" wiring for connections from previous node and to next node as required. Each 4-NET-MM supports one multi-mode fiber pair between network cards.
4-NET-SM	Single-mode fiber-optic SFP Network Controller	Single mode 9/125 μ (G.652) fiber pair up to 6.2 miles (10 km). Order one 4-NET-SM for "in" wiring from the previous node and a second 4-NET-SM for "out" network wiring to the next node. Each 4-NET-SM supports one single-mode fiber pair between network cards
4-NET-SMH	Single-mode fiber-optic SFP Network Controller High output	Single-mode fiber-optic, high-power output, with a 9/125 μ (G.652) fiber pair up to 24.8 mi (40km). Order one 4-NET-SMH for "in" wiring from the previous node and a second 4-NET-SMH for "out" network wiring to the next node. Each 4-NET-SMH supports one single-mode fiber pair between network cards.
4-NET-SMU	Single-mode fiber-optic SFP Network Controller Bi-Directional	Bi-directional, single-mode fiber-optic with a 9/125 μ (G.652) fiber up to 6.2 miles (10 km). The 4-NET-SMU must be paired with a 4-NET-SMD over one single-mode fiber between network cards.
4-NET-SMD	Single-mode fiber-optic SFP Network Controller Bi-Directional	Bi-directional, single-mode fiber-optic with a 9/125 μ (G.652) fiber up to 6.2 miles (10 km). The 4-NET-SMD must be paired with a 4-NET-SMU over one single-mode fiber between network cards.
4-NET-TP	2 Mbps Twisted Pair SFP Network Controller	Twisted pair. Following specifications are between any two panels. <ul style="list-style-type: none"> • 16 to 22 AWG (1.3 to 0.33 mm²) • Six twists per foot minimum • Circuit Capacitance 0.09 μF max. • 5,000 ft. (1,524 m) between any two panels • Circuit resistance 90 Ω max.
4-NET-TP-HC	0.3 Mbps Twisted Pair SFP Network Controller	Twisted pair or Shielded twisted pair. Following specifications are between any two panels. <ul style="list-style-type: none"> • 16 to 24 AWG (1.3 to 0.20 mm²) • Six twists per foot minimum • 5,000 ft. (1,524 m) between any two nodes with unshielded twisted pair • Circuit capacitance 0.3 μF max. • 3280 ft. (1,000 m) between any two nodes shielded twisted pair • Circuit resistance 90 Ω max.

Refer to Data Sheet E85014-0008 for additional details on SFP network controllers.

Technical Specifications

Annunciator Assemblies

Each annunciator space holds a control-display module. LCD displays, 4-MIC and 4-FT take two spaces.

	4-2ANN	4-4ANN	4-6ANN	4-8ANN	4-16ANN	4-24ANN
Number of Spaces	Two	Four	Six	Eight	Sixteen	Twenty-four
Wallbox, Surface Mounting	4-2ANNMT	4-4ANNMT	4-ANNMT	4-8ANNMT	4-16ANNMT	4-24ANNMT
Wallbox, Semi-flush Mounting				3-CAB5B	3-CAB7B	3-CAB14B
Agency Approvals:	UL, ULC, FM, CSFM					
Door Color	Metallic Bronze (Pantone Coated PMS# P 171-16 C, Pantone RGB# 81 75 67, and RAL Classic/RAL Design# 7022)					
Wallbox Color	Black					

4-ANNCPU Central Processor

Comes standard with annunciator assemblies.

Voltage	16 to 32Vdc
Current draw	
Standby	183 mA at 16 VDC; 125 mA at 24 VDC; 119 mA at 32 VDC
Alarm/Active	188 mA at 16 VDC; 125 mA at 24 VDC; 124 mA at 32 VDC
USB support	One USB 3.0, Type A – female port One USB 3.0, Type B – female port
SFP support	Supports all 4-NET series SFPs. Refer to EST4 Network Controllers Catalog sheet 85014-0008 for details.
Wire Size	TB1 backup power connection 12 to 18 AWG (2.5 to 1.0 mm ²)
Operating Temperature	32 to 120°F (0 to 49°C)
Operating relative Humidity	0 to 93% noncondensing
Option modules	4-ANNAUDTEL: Annunciator Audio/Telephone interface module. Adds audio and telephone processing capabilities to the 4-ANNCPU, required for the use of the 4-MIC and/or 4-FT with the 4-ANNCPU.

Ordering Information, annunciators and accessories

Model # (SKU)	Description	Shipping Weight
4-2ANN	LCD Annunciator - Comes with 4-LCDANN color touchscreen display, 4-ANNCPU, metallic bronze outer door and black inner door. Order wallbox assembly model 4-2ANNMT and required network Controllers 4-NET-XX separately (see Note 1).	10.3lb (4.67kg)
4-4ANN	Metallic bronze Annunciator supports 4 slots (1 row of 4). Comes with 4-ANNCPU, metallic bronze outer door and black inner door. Order wall Mounting assembly 4-4ANNMT, required network controllers 4-NET-XX series (See note 1), any user interfaces and filler plates separately.	11.5lb (5.22kg)
4-6ANN	Metallic bronze Annunciator, 6 slots (1 row of 6). Comes with 4-ANNCPU, metallic bronze outer door and black inner door. Order wall Mounting assembly 4-6ANNMT, required network Controllers 4-NET-XX series (see Note 1), any user interfaces and required filler plates separately.	12.5lb (5.67kg)
4-8ANN	Metallic bronze Annunciator, 8 slots (2 rows of 4). Comes with 4-ANNCPU, metallic bronze outer and black inner doors. Order wall Mounting assembly 4-8ANNMT (surface mounting), or 3-CAB5B (Semi-flush mounting) required network Controllers 4-NET-XX series (see Note 1), End User interfaces and required filler plates separately.	24.5lb (11.11kg)
4-16ANN	Metallic bronze Annunciator, 16 slots (2 rows of 8). Comes with 4-ANNCPU, metallic bronze outer and black inner doors. Order wall Mounting assembly 4-16ANNMT (Surface mount) or 3-CAB7B (semi-flush mount), required network Controllers 4-NET-XX series (see Note 1), end user interfaces and required filler plates separately.	37.9lb (17.19kg)
4-24ANN	Metallic bronze Annunciator, 24 slots (3 rows of 8). Comes with 4-ANNCPU, metallic bronze outer and black inner doors. Order wall mounting assembly 4-24ANNMT, required network Controllers 4-NET-XX series (see Note 1), and End User interfaces and required filler plates separately.	52.9lb (24.02kg)

Accessories and Related Equipment

4-LCDANN	Color LCD display, includes silicon rubber common control buttons, mounts in remote annunciators, communicates to 4-ANNCPU. Comes with interconnect cable. LCD ordered separately for mounting in 4-4ANN or 4-6ANN. 4-2ANN comes with one 4-LCDANN.	1.90lb (0.85kg)
4-LCDLE	Color LCD display, includes silicon rubber common control buttons, mounts in remote annunciators sizes 4-8ANN, 4-16ANN or 4-24ANN, communicates to 4-ANNCPU. Comes with interconnect cable	1.9lb (0.85kg)
4-LCDAUD TELANN	LCD display for control of paging and fire fighter telephone. Comes with one 4-LCDAUDEL and mounting and cabling hardware for mounting in 4-16ANNMT or 4-24ANNMT enclosures where separate LCD display of Audio and Telephone is required. Is not supported in other annunciator sizes. Order annunciator application specific equipment separately.	1.8lb (0.81kg)
4-ANNCPU	Annunciator Central Processor Unit (CPU), provides mounting for up to two network controllers (see note 1), one USB device port, one USB host port and one 4-ANNAUDEL module.	1.0lb (0.45kg)
4-24L	Control Display Module with 24 indicators. See note 2.	0.6lb (0.27kg)
4-24L12S	Control Display Module with 24 indicators and 12 switches. See Note 2.	0.7lb (0.29kg)
4-24L18S	Control Display Module with - 24 indicators and 18 switches. See Note 2.	0.7lb (0.29kg)
4-24L24S	Control Display Module with - 24 indicators and 24 switches. See Note 2.	0.7lb (0.29kg)
4-FIL	Fills one indicator/switch space on inner doors when no Switch or LED strips are installed.	0.1lb (0.04kg)
4-MIC	Audio paging microphone. Requires 4-ANNAUDEL support card be installed on the 4-ANNCPU card. Can be mounted in 4-4ANN through 4-24ANN annunciators	1.2lb (0.54kg)
4-FT	Master Fire Fighters telephone. Requires a 4-ANNAUDEL support card be installed on the 4-ANNCPU card. Can be mounted in 4-4ANN through 4-24ANN annunciators.	1.4lb (0.64kg)
4-ANN AUDEL	Annunciator Audio/Telephone interface module. Adds audio and telephone processing capabilities to the 4-ANNCPU, required for the use of the 4-MIC and/or 4-FT with the 4-ANNCPU.	0.3lb (0.14kg)
4-CPUGRPH	Graphic Annunciator Central Processor Module. See Note 3.	1.5lb (0.68kg)
3-EVDVR	LED/SWITCH Driver Module Assembly for ENVOY graphics. See Note 3.	0.4lb (0.18kg)
3-EVDVRA	LED/SWITCH Driver Module Assembly for Third-party Graphics. See Note 3.	0.7lb (0.32kg)
3-EVPWR	Power Supply Assembly space for one 4-CPUGRPH for ENVOY Graphics. See Note 3.	0.2lb (0.09kg)
3-EVPWRA	Power Supply Assembly c/w 19 inch rail mounting chassis assembly space for one 4-CPUGRPH for Third-party Graphics. See Note 3.	2.9lb (1.34kg)
3-EVDVRX	Plastic mounting extrusion 19" mounting - for up to 3 3-EVDVRAs. See Note 3.	0.9lb (0.41kg)

Note 1: Refer to Catalog Sheet part number E85014-0008 for a complete list and description of available Network Controllers.

Note 2: Refer to Catalog Sheet part number E85014-0006 for a complete description of Control Display Modules.

Note 3: SKU not FM approved.



LIFE SAFETY & INCIDENT MANAGEMENT

Contact us

Phone: 800-655-4497 (Option 4)
 Email: edwards.fire@carrier.com
 Website: edwardsfiresafety.com

8985 Town Center Pkwy
 Bradenton, FL 34202

© 2020 Carrier
 All rights reserved.

Ordering Information, wallboxes and replacement parts

Model # (SKU)	Description	Shipping Weight
Wallboxes		
4-2ANNMT	Mounting assembly for 4-2ANN, two wide annunciator. Supports surface or semi-flush mounting. Comes with black wallbox, surface mounting plastic fillers and semi-flush trim.	6.4lb (2.9kg)
4-4ANNMT	Mounting assembly for 4-4ANN, four wide annunciator. Supports surface or semi-flush mounting. Comes with black wallbox, surface mounting plastic fillers and semi-flush trim.	9.0lb (4.08kg)
4-6ANNMT	Mounting assembly for 4-6ANN, six wide annunciator. Supports surface or semi-flush mounting. Comes with wallbox, surface mounting plastic fillers and semi-flush trip.	10.3lb (4.67kg)
4-8ANNMT	Mounting assembly for 4-8ANN, four wide x two row high annunciator. Supports surface mounting.	19.0lb (8.62kg)
3-CAB5B	Wallbox – Black Semi-flush wallbox, ideal for use when semi-flush mounting 4-8ANN annunciators.	20.0lb (9.07kg)
4-16ANNMT	Surface Mount Wall box assembly for eight wide by two high annunciators (16 spaces)	27.0lb (12.25kg)
3-CAB7B	Wallbox – Black Semi-flush wallbox, ideal for use when semi-flush mounting 4-16ANN annunciators.	29.5lb (13.38kg)
4-24ANNMT	Surface mount wallbox assembly for eight wide by three high annunciator (24 spaces).	37.0lb (16.78kg)
3-CAB14B	Wallbox – Black Semi-flush wallbox, ideal for use when semi-flush mounting 4-24ANN annunciators.	40.8lb (18.5kg)
Service Replacement Parts		
4-2ANND	Service replacement metallic bronze Annunciator Door for 4-2ANN annunciators includes the inner and outer doors.	7.7lb (3.5kg)
4-4ANND	Service replacement metallic bronze Annunciator Door for 4-4ANN annunciators includes the inner and outer doors.	10lb (4.5kg)
4-6ANND	Service replacement metallic bronze Annunciator Door for 4-6ANN annunciators, includes the inner and outer door	11lb (5kg)
4-CAB8D	Service replacement metallic bronze door for 3-CAB5B or 4-8ANNMT - four spaces wide by two high (8 spaces) Includes inner (black) door and outer metallic bronze door.	23lb (10.4kg)
4-CAB8DR	Red door for 3-CAB5B - four spaces wide by two high (8 spaces). Includes inner (black) door and outer red door. May be used to provide a red door for 4-8ANN annunciators.	23lb (10.4kg)
4-CAB16DR	Red door for 3-CAB7B - eight spaces wide by two high (16 spaces). Includes inner (black) door and outer red door. May be used to provide a red door for 4-16ANN annunciators.	36lb (16.3kg)
4-CAB24DR	Red door for 3-CAB14B - eight spaces wide by three high (24 spaces). Includes inner (black) door and outer red door. May be used to provide a red door for 4-24ANN annunciators	51lb (23.1kg)
4-2ANNFA	Service replacement part - plastic frame assembly with mounting screws for 4-2ANN annunciators	1.5lb (0.68kg)
4-4ANNFA	Service replacement part - plastic frame assembly with mounting screws for 4-4ANN annunciators.	2lb (0.91kg)
4-6ANNFA	Service replacement part - plastic frame assembly with mounting screws for 4-6ANN annunciators.	2lb (0.91kg)
4-4X2ANNFA	Service replacement part – plastic frame assembly with mounting screws for 4-8ANN annunciators and 4-CAB5D door assemblies.	3lb (1.36kg)
4-8ANNFA	Service replacement part - plastic frame assembly with mounting screws for 4-CAB16D and 4-CAB21D(L) door assemblies.	3lb (1.36kg)



LIFE SAFETY & INCIDENT MANAGEMENT

Wall Mount Signaling Appliances

Genesis LED G4 Series



Overview

Genesis LED G4 Series horns and LED strobes feature a sleek low profile design and energy-efficient technology that makes them less expensive to install and operate by reducing overhead. High performance LEDs require fewer power supplies, backup power, and batteries. These new appliances are designed with energy-efficiency, and life safety in mind.

Genesis LED G4 Series uses high efficiency optics, combined with patented electronics, to deliver a highly controlled and efficiently focused light distribution pattern in exchange for lower current requirements. Strobes feature field-selectable 15, 30, 75, or 110 cd light output.

Compared with Xenon-type strobes, Genesis LED G4 Series appliances need fewer power supplies and often smaller wire gauge, which lightens conduit requirements. They are also backwards compatible with legacy strobes, so there's no need to replace all your existing devices to upgrade to new LED technology. In fact, G4 strobes can be mixed on the same circuit and used in the same field of view as Xenon-based strobes. This makes Genesis LED G4 Series ideal for new installations and retrofits alike.

Field-configurable sound output levels provide the flexibility modern life safety projects demand, while the Genesis LED control protocol keeps multiple strobes on compatible NAC circuits synchronized to well within NFPA 72 requirements.

Serviceability is another area where G4 Series appliances shine. The universal room side wiring plate allows for pre-installation and electrical wiring as well as checking continuity with the included diagnostics check bar. G4 Series devices can then be easily snapped into place with the confidence of knowing the wiring is correct. The innovative under-cover diagnostic test points provide easy access to device circuit testing while mounted.

Standard Features

- **High Performance LED Strobe Technology**
 - Ultra low device current consumption allows:
 - More devices per circuit
 - Ability to use lower gauge wire
 - Longer wire runs
 - Fewer booster power supplies
 - High efficiency optics
 - Selectable 15, 30, 75, or 110 cd light output
 - LED devices may be mixed with legacy Xenon strobes
- **Efficient Audible Output**
 - Selectable high or low dB horn output
 - Selectable temporal or steady horn output
 - Improved audio frequency range for better wall penetration
- **Low-profile Design**
 - Ultra-slim... protrudes about 1.5" from the mounting surface
 - Attractive appearance... no visible mounting screws
- **Multiple "FIRE" Marking Options**
 - Order English, French, Spanish or no FIRE markings
 - Change markings at any time with replaceable quick-swap covers
- **Easy to Install**
 - Pre-install and pre-wire with convenient universal room side wiring plate
 - Check electrical continuity on room side wiring plate with included diagnostics check bar
 - Diagnostics port streamlines device circuit testing
 - Fits 1-gang, 2-gang, 3.5-inch octagon, and 4-inch square electrical boxes
 - Optional red and white trim plates available
 - Slide switches for field configuration
 - 12 to 18 AWG in-out screw terminals for quick wiring

Application

Strobes

Genesis G4 Series strobes are UL 1971-listed for use indoors as wall-mounted public-mode notification appliances for the hearing impaired. Prevailing codes require strobes to be used where ambient noise conditions exceed 105 dBA (87 dBA in Canada), where occupants use hearing protection, and in areas of public accommodation as defined in the *Americans with Disabilities Act*.

Synchronization is important in order to avoid triggering seizures in people with photosensitive epilepsy. All Genesis strobes exceed UL synchronization requirements (within 10 milliseconds over a two-hour period) when used with a synchronization source. See the specifications table for a list of compatible sources.

Horns

Genesis horn output reaches as high as 92 dBA and features an improved audio frequency range compared with other Genesis horns. This results in excellent sound penetration through walls and a clear warning of danger. Horn only models may be configured for either coded or non-coded notification appliance circuits. They can also be set for high or low dBA output. This setting reduces horn output by about 6 dBA. Horn-only models may be ceiling-mounted or wall-mounted.

The suggested sound pressure level for each signaling zone used with alarm signals is at least 15 dBA above the average ambient sound level, or 5 dBA above the maximum sound level having a duration of at least 60 seconds, whichever is greater. These values are measured at five feet (1.5 m) above the floor. The average ambient sound level is A-weighted, fast response sound pressure measured over a 24-hour period.

Doubling the distance from the signal to the ear will theoretically result in a 6 dBA reduction of the received sound pressure level. The actual effect depends on the acoustic environment in the space. A 3 dBA difference represents a barely noticeable change in volume.

Installation

Genesis G4 horns and strobes mount to the required GP10 room side wiring plate. The GP10 mounting plate is ordered separately from the G4 device in packs of 10 for convenient pre-installing and pre-wiring. The device can be removed easily from the room side wiring plate by pushing up with a screwdriver. The cover can also be removed from the device easily with a screwdriver to access the light and sound output settings and a diagnostics test port for voltage testing.

Removing Cover

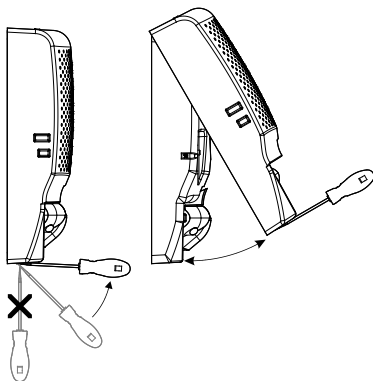

Removing Device

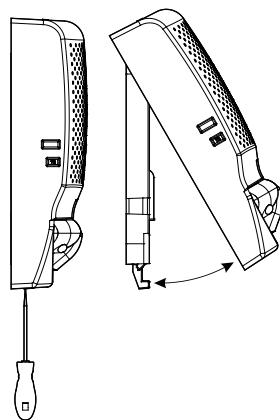

Genesis LED G4 Series horns, strobes, and horn-strobes mount to any standard one-gang, two-gang, 3.5-inch octagon, and 4-inch square electrical box. Matching optional G4T trim rings are available to cover oversized openings. Optional color matched double-gang surface boxes are also available.

Double Gang Electrical Box

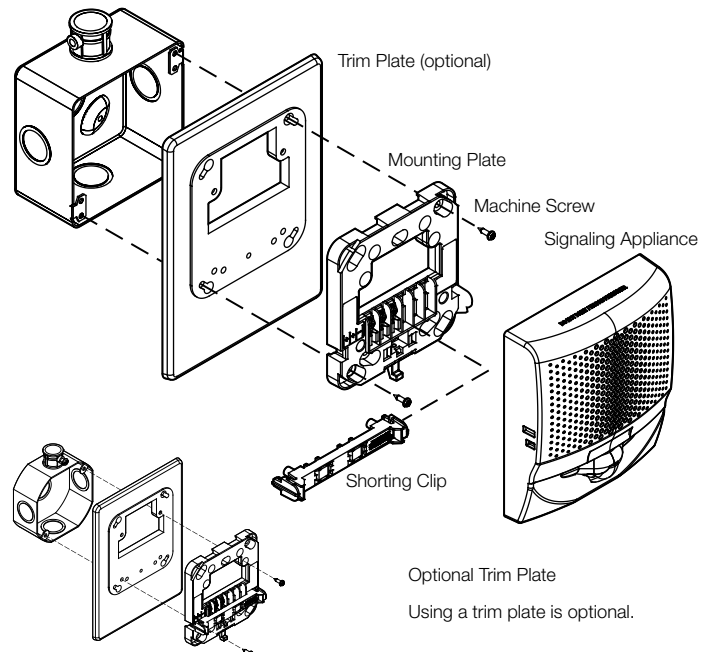

3.5-inch Octagon Electrical Box

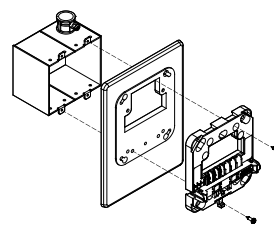

Two-gang Electrical Box

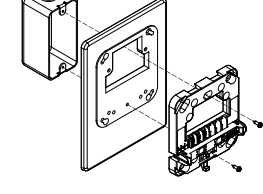

One-gang Electrical Box

Optional Trim Plate
Using a trim plate is optional.

Wiring

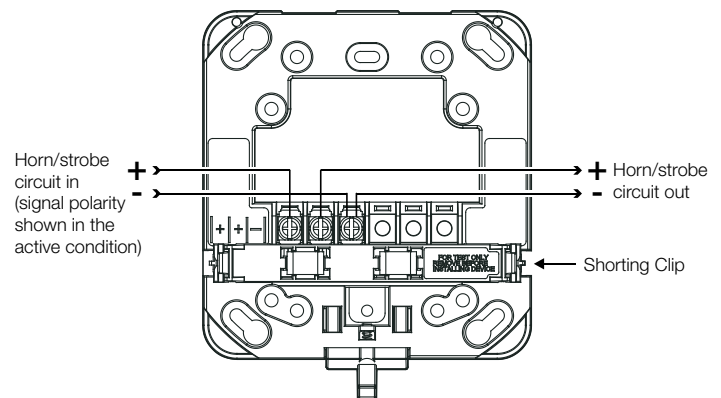

Dimensions

G4 Notification Appliances

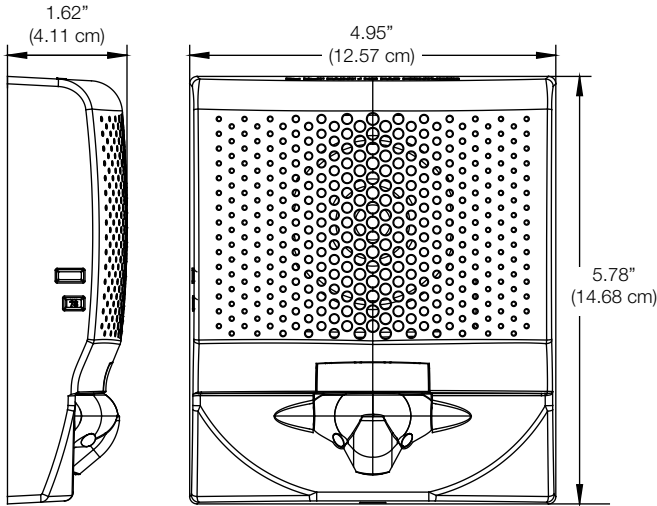

G4T Trim Plate (optional)

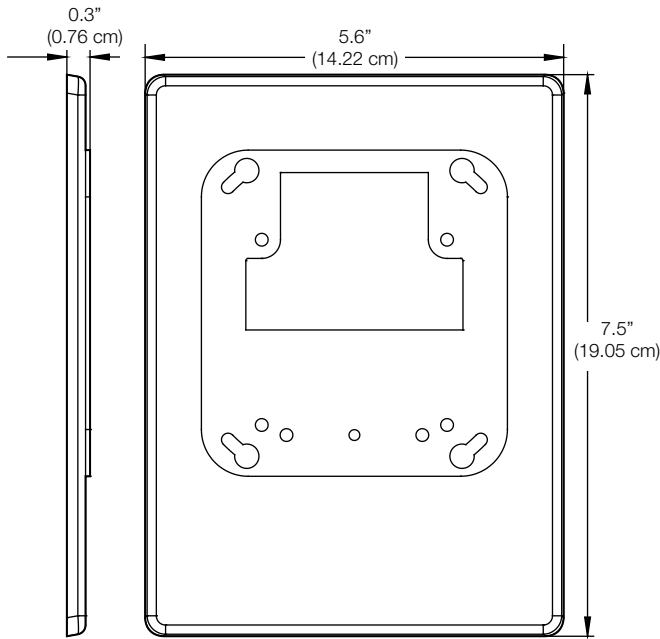

Diagnostics

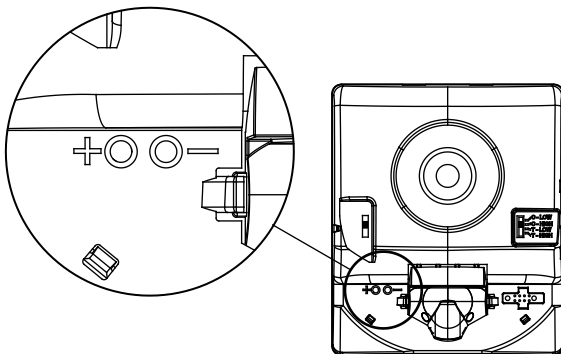

Test points indicated above are used to validate the Notification Appliance Circuit and verify device function.

Field Configuration

Temporal horn and horn-strobe models are factory set to sound in a three-pulse temporal pattern. By sliding the tone selector switch, horn only models may be configured for constant horn output that can be coded at precise intervals by EDWARDS control panels and control modules.

Note: Temporal 3 coding is the required output for fire notification devices per NFPA 72. Any device coding other than temporal 3 is at the discretion and approval of the local authority having jurisdiction (AHJ).

Horns and horn-strobes are factory set for high dB output. Low dB output may be selected by sliding the tone selector switch. This reduces the output by about 6 dBA.

Genesis LED clear strobes and horn-strobes may be set for 15, 30, 75, or 110 candela output. The output setting is changed by simply removing the cover and sliding the candela switch to the desired setting. The device does not have to be removed from the wall to change the output setting. The setting remains visible through a small window on the left-hand side of the device after the cover is closed.

Light and Sound Output Settings

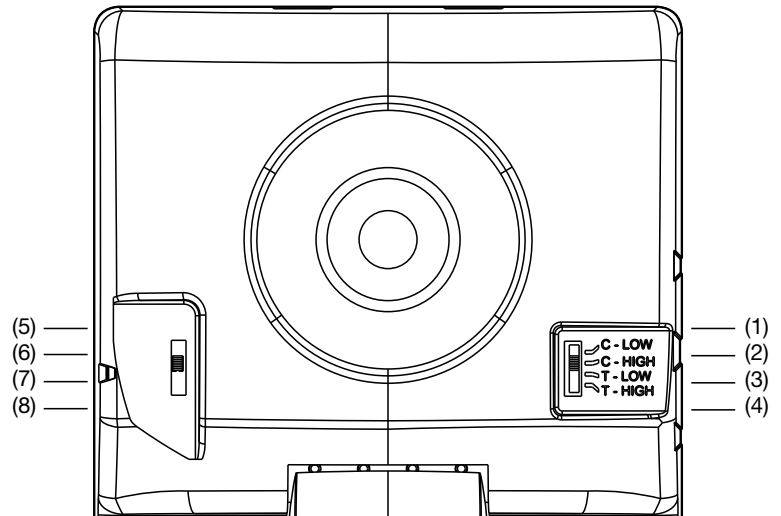

- (1) Constant, low dB
- (2) Constant, high dB
- (3) T3 temporal, low dB
- (4) T3 temporal, high dB
- (5) 110 candela
- (6) 75 candela
- (7) 30 candela
- (8) 15 candela

Operating current

Horns

Sound setting	16 to 33 VDC	16 to 33 VFWR
C-Low, T-Low	18 mA	22 mA
C-High, T-High	28 mA	38 mA

Strobes

Strobe setting	16 to 33 VDC	16 to 33 VFWR
15, 30, 75, 110	28 mA	36 mA

Horn-Strobes

Strobe setting	Sound setting	16 to 33 VDC	16 to 33 VFWR
15, 30, 75, 110	C-Low, T-Low	40 mA	48 mA
	C-High, T-High	50 mA	60 mA

Sound Output

Horn & Horn-Strobe

Sound setting	Reverberant (UL464)	Anechoic (CAN/ULC - 5925)
C-Low, T-Low	80 dBA	86 dBA
C-High, T-High	85 dBA	92 dBA

Sound pattern (ULC)

Axis	Angle	Change in output
Horizontal	135° and 45°	-3 dBA
	150° and 30°	-6 dBA
Vertical	135° and 40°	-3 dBA
	150° and 30°	-6 dBA

Light Distribution

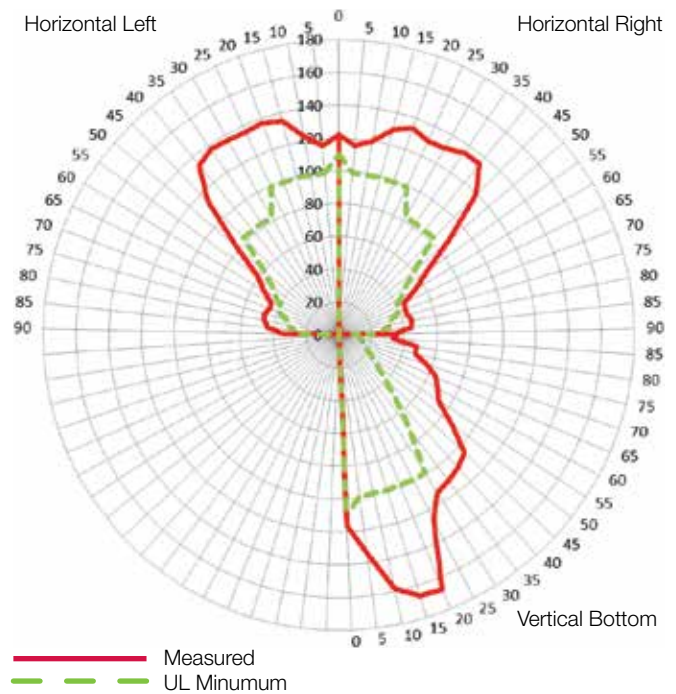

Specifications

Operating voltage	16 to 33 VDC, 16 to 33 VFWR
Horn signal type	Constant or TC3 temporal
Light output	15, 30, 75, or 110 candela
Strobe flash rate	1 fps (flash per second) approx.
Synchronization	20 Ω max. between any two devices. To determine allowed wire resistance, refer to these specifications, and the specifications for the synchronized signal source.
Synchronization Sources	Edwards CC Series Signal Modules, Booster and Auxiliary Power Supplies, Intelligent and Conventional Control Panels
Wire size	12 to 18 AWG (0.75 to 2.50 mm ²)
Dimensions (W×H×D)	4.95 x 5.78 x 1.62 in (12.57 x 14.68 x 4.11 cm)
Strobe-to-box center offset	-1.70 inches (-4.32 cm)
Compatible electrical boxes [1]	1-gang, 2-gang, 3.5-inch octagon, 4-inch square
Trim plates	G4TR, G4TW (5.6 x 7.5 x 0.3 in (14.22 x 19.05 x 0.76 cm))
Operating environment	
Temperature	32 to 122°F (0 to 50°C)
Relative humidity	0 to 93% noncondensing
Storage Temperature	-40 to 158 F (-40 to 70 C)

[1] Electrical boxes must be at least 1-1/2 in. (3.81 cm) deep.

Ordering Information

FOR REFERENCE ONLY

Notification Appliances		Color	Marking
 Horns	G4ARF	Red	FIRE
	G4ARF-FR	Red	FEU
	G4ARF-SP	Red	FUEGO
	G4ARN	Red	None
	G4AWF	White	FIRE
	G4AWF-FR	White	FEU
	G4AWF-SP	White	FUEGO
	G4AWN	White	None

Replacement Appliance Covers		Color	Marking
 Horn Covers	G4ARA-CVR	Red	ALERT
	G4ARF-CVR	Red	FIRE
	G4ARF-FR-CVR	Red	FEU
	G4ARF-SP-CVR	Red	FUEGO
	G4ARN-CVR	Red	None
	G4AWA-CVR	White	ALERT
	G4AWF-CVR	White	FIRE
	G4AWF-FR-CVR	White	FEU
	G4AWF-SP-CVR	White	FUEGO
	G4AWN-CVR	White	None



 Strobes	G4VRF	Red	FIRE
	G4VRF-FR	Red	FEU
	G4VRF-SP	Red	FUEGO
	G4VRN	Red	None
	G4VWF	White	FIRE
	G4VWF-FR	White	FEU
	G4VWF-SP	White	FUEGO
	G4VWN	White	None

 Strobe Covers	G4VRA-CVR	Red	ALERT
	G4VRF-CVR	Red	FIRE
	G4VRF-FR-CVR	Red	FEU
	G4VRF-SP-CVR	Red	FUEGO
	G4VRN-CVR	Red	None
	G4VWA-CVR	White	ALERT
	G4VWF-CVR	White	FIRE
	G4VWF-FR-CVR	White	FEU
	G4VWF-SP-CVR	White	FUEGO
	G4VWN-CVR	White	None

 Horn-strobes	G4AVRF	Red	FIRE
	G4AVRF-FR	Red	FEU
	G4AVRF-SP	Red	FUEGO
	G4AVRN	Red	None
	G4AVWF	White	FIRE
	G4AVWF-FR	White	FEU
	G4AVWF-SP	White	FUEGO
	G4AVWN	White	None

 Horn-strobe Covers	G4AVRA-CVR	Red	ALERT
	G4AVRF-CVR	Red	FIRE
	G4AVRF-FR-CVR	Red	FEU
	G4AVRF-SP-CVR	Red	FUEGO
	G4AVRN-CVR	Red	None
	G4AWA-CVR	White	ALERT
	G4AVWF-CVR	White	FIRE
	G4AVWF-FR-CVR	White	FEU
	G4AVWF-SP-CVR	White	FUEGO
	G4AVWN-CVR	White	None

Accessories

	GP10	Room Side Wiring Plate (required, ordered separately)		G4TR	Trim plate, G4 Series, red		G4TW	Trim plate, G4 Series, white
			27193-21	Two-gang surface mount box, red		27193-26	Two-gang surface mount box, white	

Model Number Syntax, Appliances

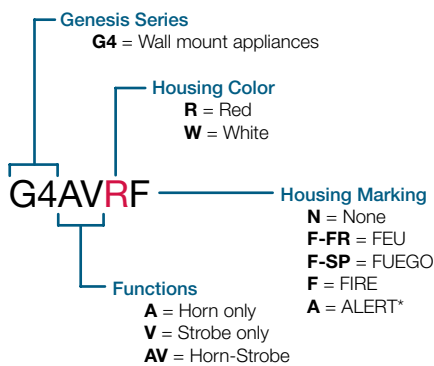

* ALERT Marking available on white strobe model only. See replacement covers for more options.

Model Number Syntax, Replacement Covers

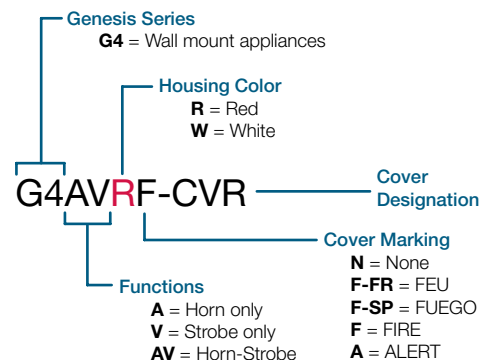



LIFE SAFETY & INCIDENT MANAGEMENT

Contact us...

Email: edwards.fire@fs.utc.com
Web: edwards-fire.com

1016 Corporate Park Drive
Mebane, NC 27302

EDWARDS is a registered mark in the
United States and other countries.

© 2019 United Technologies Corporation.
All rights reserved.



LIFE SAFETY & INCIDENT MANAGEMENT

Genesis LED GC Series

Ceiling Mount

Notification Devices

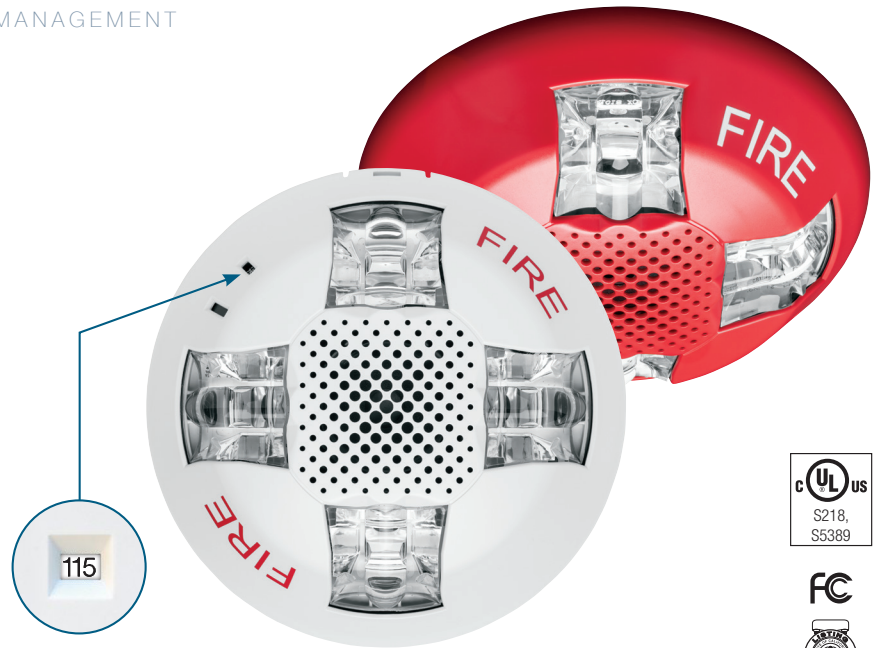

FC



Overview

Genesis LED GC Series horns and LED strobes feature a sleek low profile design and energy-efficient technology that makes them less expensive to install and operate by reducing overhead. High performance LEDs require fewer power supplies, backup power, and batteries. These new appliances are designed with, energy-efficiency, and life safety in mind.

Genesis LED GC Series uses high efficiency optics, combined with patented electronics, to deliver a highly controlled and efficiently focused light distribution pattern in exchange for lower current requirements. Strobes feature field-selectable 15, 30, 75, or 115 cd light output.

Compared with Xenon-type strobes, Genesis LED GC Series appliances need fewer power supplies and often smaller wire gauge, which lightens conduit requirements. They are also backwards compatible with legacy strobes, so there's no need to replace all your existing devices to upgrade to new LED technology. In fact, GC strobes can be mixed on the same circuit and used in the same field of view as Xenon-based strobes. This makes Genesis LED GC Series ideal for new installations and retrofits alike.

Field-configurable sound output levels provide the flexibility modern life safety projects demand, while the Genesis LED control protocol keeps multiple strobes on compatible NAC circuits synchronized to well within NFPA 72 requirements.

Serviceability is another area where GC Series appliances shine. The universal room side wiring plate allows for pre-installation and electrical wiring as well as checking continuity with the included diagnostics check bar. GC Series devices can then be easily snapped into place with the confidence of knowing the wiring is correct. The innovative under-cover diagnostic test points provide easy access to device circuit testing while mounted.

Standard Features

- **High Performance LED Strobe Technology**
 - Ultra low device current consumption allows:
 - More devices per circuit
 - Ability to use lower gauge wire
 - Longer wire runs
 - Fewer booster power supplies
 - High efficiency optics
 - Selectable 15, 30, 75, or 115 cd light output
 - LED devices may be mixed with legacy Xenon strobes
- **Efficient Audible Output**
 - Selectable high or low dB horn output
 - Selectable temporal or steady horn output
 - Improved audio frequency range for better wall penetration
- **Low-profile Design**
 - Ultra-slim... protrudes about 1.5" from the mounting surface
 - Attractive appearance... no visible mounting screws
- **Multiple "FIRE" Marking Options**
 - Order English, French, Spanish or no FIRE markings
 - Change markings at any time with replaceable quick-swap covers
- **Easy to Install**
 - Pre-install and pre-wire with convenient universal room side wiring plate
 - Check electrical continuity on room side wiring plate with included diagnostics check bar
 - Diagnostics port streamlines device circuit testing
 - Fits 1-gang, 2-gang, 4-inch octagon, and 4-inch square electrical boxes
 - Optional red and white trim plates available
 - Slide switches for field configuration
 - 12 to 18 AWG in-out screw terminals for quick wiring

Application

Strobes

Genesis GC Series strobes are UL 1971-listed for use indoors as ceiling-mounted public-mode notification appliances for the hearing impaired. Prevailing codes require strobes to be used where ambient noise conditions exceed 105 dBA (87 dBA in Canada), where occupants use hearing protection, and in areas of public accommodation as defined in the *Americans with Disabilities Act*.

Synchronization is important in order to avoid triggering seizures in people with photosensitive epilepsy. All Genesis strobes exceed UL synchronization requirements (within 10 milliseconds over a two-hour period) when used with a synchronization source. See the specifications table for a list of compatible sources.

Horns

Genesis horn output reaches as high as 92 dBA and features an improved audio frequency range compared with other Genesis horns. This results in excellent sound penetration through walls and a clear warning of danger. Horn only models may be configured for either coded or non-coded notification appliance circuits. They can also be set for high or low dBA output. This setting reduces horn output by about 6 dBA.

The suggested sound pressure level for each signaling zone used with alarm signals is at least 15 dBA above the average ambient sound level, or 5 dBA above the maximum sound level having a duration of at least 60 seconds, whichever is greater. These values are measured at five feet (1.5 m) above the floor. The average ambient sound level is A-weighted, fast response sound pressure measured over a 24-hour period.

Doubling the distance from the signal to the ear will theoretically result in a 6 dBA reduction of the received sound pressure level. The actual effect depends on the acoustic environment in the space. A 3 dBA difference represents a barely noticeable change in volume.

Installation

Genesis GC horns and strobes mount to the required GP10 room side wiring plate. The GP10 mounting plate is ordered separately from the GC device in packs of 10 for convenient pre-installing and pre-wiring. The device can be removed easily from the room side wiring plate by pushing up with a screwdriver. The cover can also be removed from the device easily with a screwdriver to access the light and sound output settings and a diagnostics test port for voltage testing.

Removing Cover

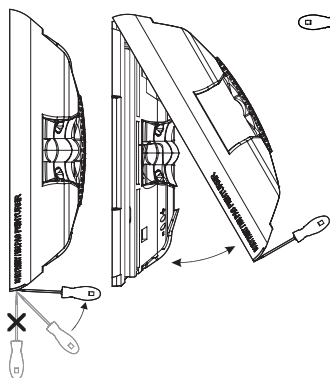

Removing Device

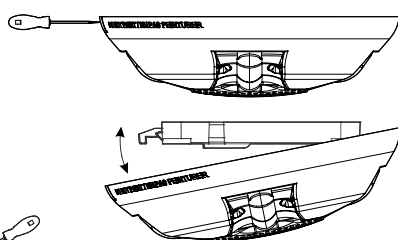

Genesis LED GC Series horns, strobes, and horn-strobes mount to any standard one-gang, two-gang, 4-inch octagon, and 4-inch square electrical box. Matching optional GCT trim rings are available to cover oversized openings. Optional color matched double-gang surface boxes are also available. Genesis LED GC series are listed to be both wall mounted or ceiling mounted.

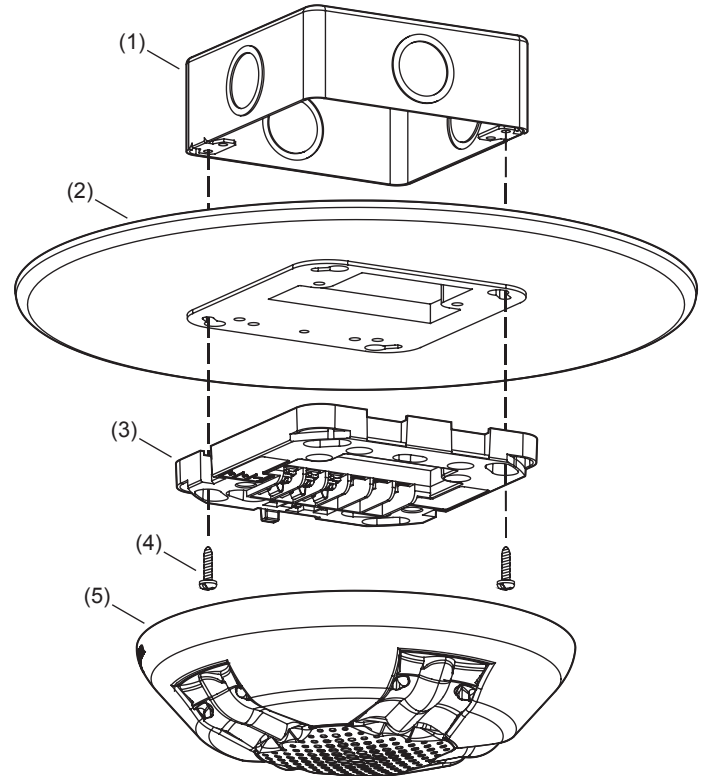

- (1) Electrical Box
- (2) Trim Plate (optional)
- (3) Wiring plate (required, ordered separately)
- (4) Machine screw (2X, supplied with wiring plate)
- (5) GC signaling appliance

Wiring

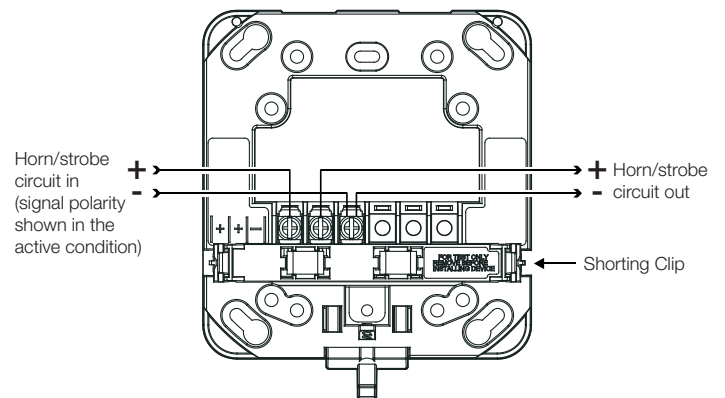

Dimensions

GC Notification Appliances

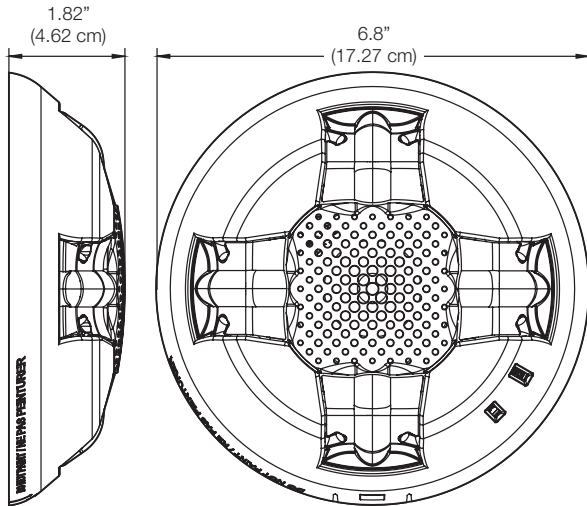

GCT Trim Plate (optional)

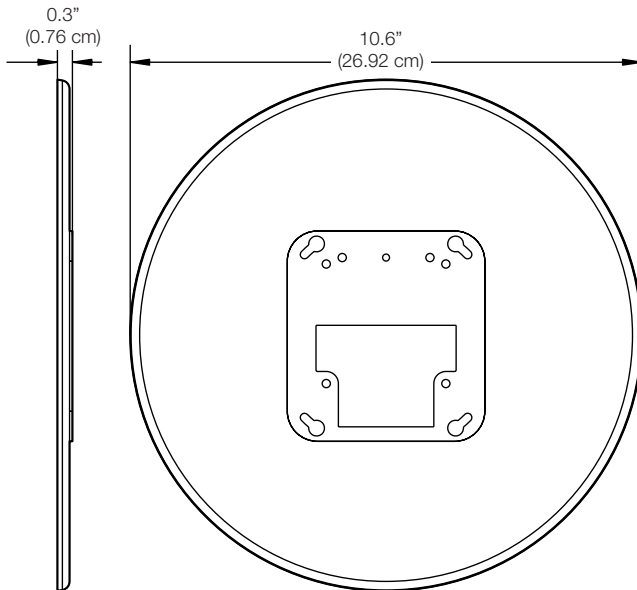

Diagnostics

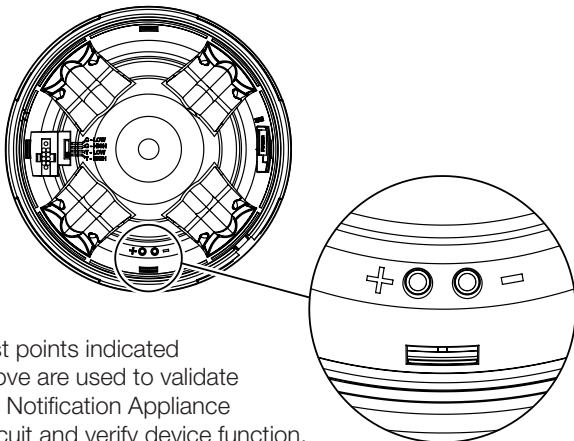

Test points indicated above are used to validate the Notification Appliance Circuit and verify device function.

Field Configuration

Temporal horn and horn-strobe models are factory set to sound in a three-pulse temporal pattern. By sliding the tone selector switch, horn only models may be configured for constant horn output that can be coded at precise intervals by EDWARDS control panels and control modules.

Note: Temporal 3 coding is the required output for fire notification devices per NFPA 72. Any device coding other than temporal 3 is at the discretion and approval of the local authority having jurisdiction (AHJ).

Horns and horn-strobes are factory set for high dB output. Low dB output may be selected by sliding the tone selector switch. This reduces the output by about 6 dBA.

Genesis LED clear strobes and horn-strobes may be set for 15, 30, 75, or 115 candela output. The output setting is changed by simply removing the cover and sliding the candela switch to the desired setting. The device does not have to be removed from the wall to change the output setting. The setting remains visible through a small window on the device after the cover is closed.

Light and Sound Output Settings

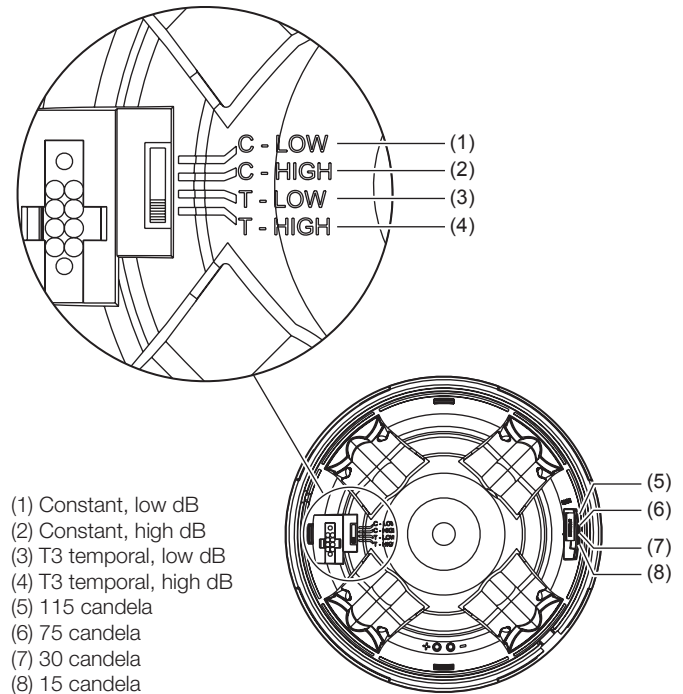

- (1) Constant, low dB
- (2) Constant, high dB
- (3) T3 temporal, low dB
- (4) T3 temporal, high dB
- (5) 115 candela
- (6) 75 candela
- (7) 30 candela
- (8) 15 candela

Operating current

Horns

Sound setting	16 to 33 VDC	16 to 33 VFWR
C-Low, T-Low	20 mA	25 mA
C-High, T-High	30 mA	40 mA

Strobes

Strobe setting	16 to 33 VDC	16 to 33 VFWR
15, 30, 75, 115	35 mA	45 mA

Horn-Strobes

Strobe setting	Sound setting	16 to 33 VDC	16 to 33 VFWR
15, 30, 75, 115	C-Low, T-Low	50 mA	60 mA
	C-High, T-High	60 mA	75 mA

Sound Output

Horn & Horn-Strobe

Sound setting	Reverberant (UL464)	Anechoic (CAN/ULC - 5925)
C-Low, T-Low	80 dBA	86 dBA
C-High, T-High	86 dBA	92 dBA

Sound pattern – Horn Models (ULC)

Axis	Angle (°)	Output (dBA)
Horizontal	115 and 55	93.3
Vertical	125 and 50	91.7

Sound pattern – Horn-Strobe Models (ULC)

Axis	Angle (°)	Output (dBA)
Horizontal	145 and 35	93.0
	155 and 35	90.8
Vertical	135 and 35	92.0
	155 and 25	85.4

Light Distribution

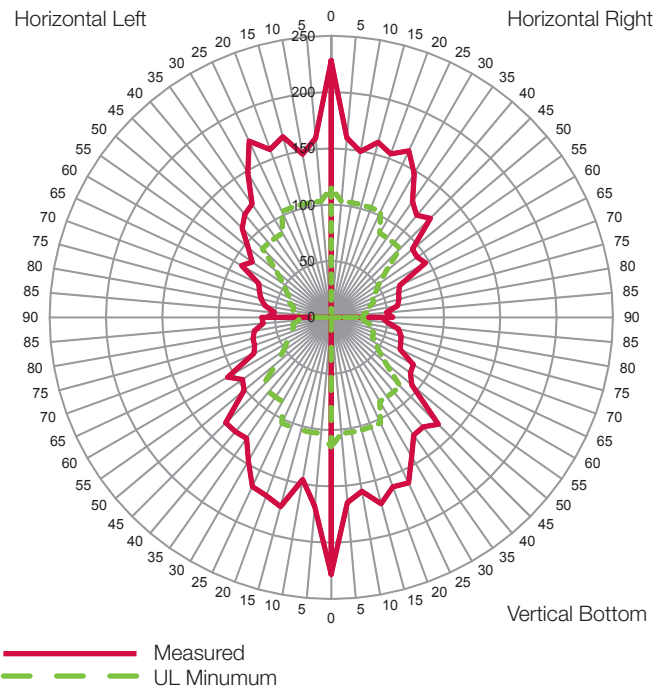

Specifications

Operating voltage	16 to 33 VDC, 16 to 33 VFWR
Horn signal type	Constant or TC3 temporal
Light output	15, 30, 75, or 115 candela
Strobe flash rate	1 fps (flash per second) approx.
Synchronization	20 Ω max. between any two devices. To determine allowed wire resistance, refer to these specifications, and the specifications for the synchronized signal source.
Synchronization Sources	Edwards CC Series Signal Modules, Booster and Auxiliary Power Supplies, Intelligent and Conventional Control Panels
Wire size	12 to 18 AWG (0.75 to 2.50 mm ²)
Mounting	Wall or Ceiling mount
Dimensions (Ø × D)	6.8 × 1.82 in. (17.27 × 4.62 cm)
Strobe-to-box center offset	-1.70 inches (-4.32 cm)
Compatible electrical boxes [1]	1-gang, 2-gang, 4-inch octagon, 4-inch square
Trim plates	GCTR, GCTW 10.6 × 0.3 in. (26.92 × 0.76 cm)
Operating environment	
Temperature	32 to 122°F (0 to 50°C)
Relative humidity	0 to 93% noncondensing
Storage Temperature	-40 to 158 F (-40 to 70 C)

[1] Electrical boxes must be at least 1-1/2 in. (3.81 cm) deep.

Ordering Information

Notification Appliances	Color	Marking
 <p>Horns</p>	GCARF	Red FIRE
	GCARF-FR	Red FEU
	GCARF-SP	Red FUEGO
	GCARN	Red None
	GCAWF	White FIRE
	GCAWF-FR	White FEU
	GCAWF-SP	White FUEGO
	GCAWN	White None

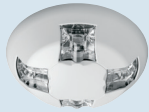
 <p>Strobes</p>	GCVRF	Red FIRE
	GCVRF-FR	Red FEU
	GCVRF-SP	Red FUEGO
	GCVRN	Red None
	GCWVF	White FIRE
	GCWVF-FR	White FEU
	GCWVF-SP	White FUEGO
	GCWWN	White None

 <p>Horn-strobes</p>	GCAVRF	Red FIRE
	GCAVRF-FR	Red FEU
	GCAVRF-SP	Red FUEGO
	GCAVRN	Red None
	GCAWVF	White FIRE
	GCAWVF-FR	White FEU
	GCAWVF-SP	White FUEGO
	GCAWWN	White None

Replacement Appliance Covers	Color	Marking
 <p>Horn Covers</p>	GCARA-CVR	Red ALERT
	GCARF-CVR	Red FIRE
	GCARF-FR-CVR	Red FEU
	GCARF-SP-CVR	Red FUEGO
	GCARN-CVR	Red None
	GCAWA-CVR	White ALERT
	GCAWF-CVR	White FIRE
	GCAWF-FR-CVR	White FEU
GCAWF-SP-CVR	White FUEGO	
GCAWN-CVR	White None	

 <p>Strobe Covers</p>	GCVRA-CVR	Red ALERT
	GCVRF-CVR	Red FIRE
	GCVRF-FR-CVR	Red FEU
	GCVRF-SP-CVR	Red FUEGO
	GCVRN-CVR	Red None
	GCVWA-CVR	White ALERT
	GCVWF-CVR	White FIRE
	GCVWF-FR-CVR	White FEU
GCVWF-SP-CVR	White FUEGO	
GCVWN-CVR	White None	

 <p>Horn-strobe Covers</p>	GCAVRA-CVR	Red ALERT
	GCAVRF-CVR	Red FIRE
	GCAVRF-FR-CVR	Red FEU
	GCAVRF-SP-CVR	Red FUEGO
	GCAVRN-CVR	Red None
	GCAWA-CVR	White ALERT
	GCAWVF-CVR	White FIRE
	GCAWVF-FR-CVR	White FEU
GCAWVF-SP-CVR	White FUEGO	
GCAWWN-CVR	White None	

Accessories



GP10

Room Side Wiring Plate (required, ordered separately)



GCTR

Trim plate, GC Series, red



GCTW

Trim plate, GC Series, white

27193-21

Two-gang surface mount box, red

27193-26

Two-gang surface mount box, white

Model Number Syntax, Appliances

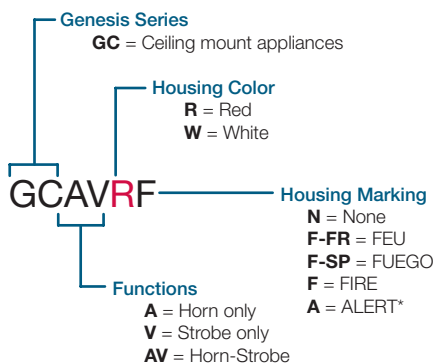

* ALERT Marking available on white strobe model only. See replacement covers for more options.

Model Number Syntax, Replacement Covers

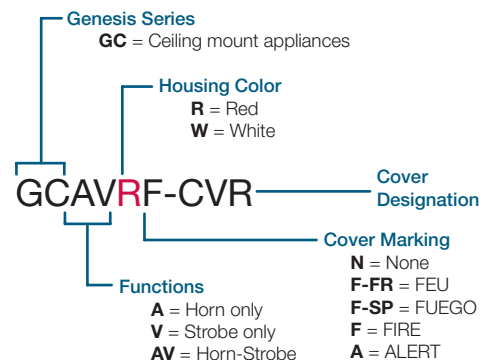



LIFE SAFETY & INCIDENT MANAGEMENT

Contact us...

Email: edwards.fire@fs.utc.com
Web: edwards-fire.com

8985 Town Center Pkwy.
Bradenton, FL 34202

EDWARDS is a registered mark in the
United States and other countries.

© 2019 United Technologies Corporation.
All rights reserved.
